

Quantum QE Series

Exhaust air heat pump



Installation and user handbook

QCH EN 2410-2
TD3

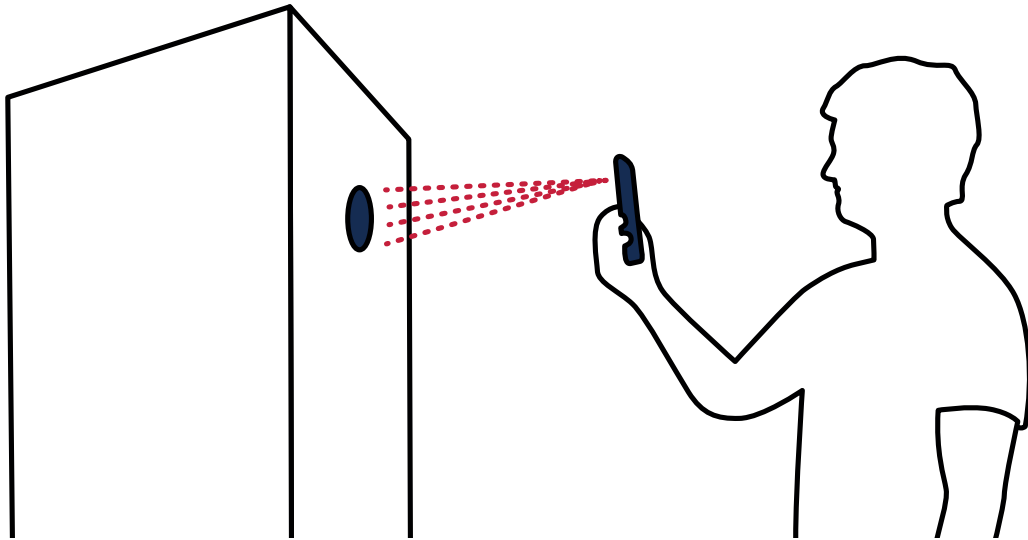

QVANTUM APP

Have all the controls for your heat pump,
in the palm of your hand.

Quantum app is a necessary companion for installing and setting up your Q unit. The app is available on both App Store and Google Play.

By scanning the QR code on your Q unit, you can connect to the unit through Wi-Fi or Bluetooth. During commissioning, you will be guided through the entire installation process.

Once the connection is established, you can use the app to access all relevant information and settings for your product.

CONTENTS

1 Important information.....	3	Technical data.....	28
General.....	3	Energy labelling.....	29
Safety.....	3	Index.....	32
Symbols.....	3		
Product labels.....	3		
Serial number and QR code.....	3		
Environmental information.....	3		
Glossary.....	3		
2 Before installing.....	5		
Transport.....	5		
Installation area.....	5		
Additional components.....	5		
Front cover removal.....	6		
3 Components.....	8		
Overview.....	8		
Hydronic unit connections.....	8		
Ventilation unit.....	8		
Electrical box.....	9		
4 Pipe and ventilation installation.....	10		
Pipe installation, general.....	10		
Pipe connections.....	11		
Installation.....	11		
Ventilation installation, general.....	12		
5 Electrical installation.....	15		
Electrical installation, general.....	15		
Electrical connections.....	16		
Safety temperature limiter.....	18		
6 Commissioning.....	19		
Quantum app.....	19		
Preparations.....	19		
Filling.....	19		
Venting.....	20		
First start-up.....	20		
7 User interface.....	21		
Introduction.....	21		
Using the display unit.....	21		
Display pages.....	21		
8 Service.....	23		
General.....	23		
Maintenance.....	23		
Service actions.....	24		
9 Comfort disturbance.....	26		
Troubleshooting.....	26		
10 Technical specifications.....	28		
Dimensions and installation coordinates.....	28		

1 IMPORTANT INFORMATION

General

⚠ WARNING

Read this manual before starting the heat pump for the first time.

It is the owner of the heat pump that is responsible for the system. If you suspect that the product is defective, contact your dealer.

Safety

This manual contains installation and servicing procedures that must be performed by a professional.

The manual must be available for people who install, support or use the heat pump.

⚠ CAUTION

This appliance can be used by children from 8 years and above and people with reduced physical, sensory or mental capabilities or lack of experience and knowledge if they have been given supervision or instruction concerning the use of the appliance in a safe way and understand the hazards involved. Children must not play with the appliance. Cleaning and maintenance must not be performed by children unless they are older than 8 and supervised.

Symbols

The manual contains the following symbols

⚠ WARNING

This symbol describes information that is of great danger to people or equipment.

⚠ CAUTION

This symbol describes information that could cause danger to people or equipment.

👉 NOTE

This symbol describes information that is crucial when installing or servicing the heat pump.

ℹ TIP

This symbol describes information that can be helpful when installing or servicing the heat pump.

Product labels

These labels are found on the product.

CE CE marking indicates that a product has been assessed by the manufacturer and deemed to meet EU safety, health and environmental protection requirements.

IP21 Protection classification against water and dust in the electrical enclosure.

Serial number and QR code

The serial number and QR code of the QE are visible at the following locations.

- Electrical box cover
- Packaging
- Display unit.

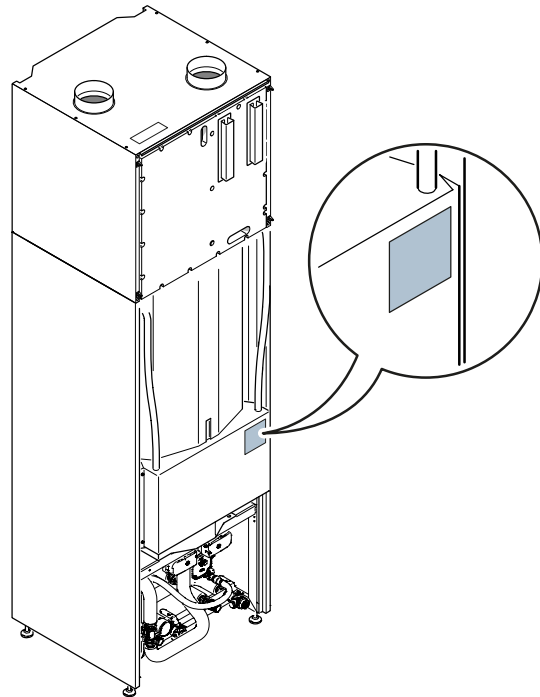

Environmental information

F-gas regulation (EU) No. 517/2014

This product contains a fluorinated greenhouse gas that is covered by the Kyoto protocol.

The equipment contains R134a, a fluorinated greenhouse gas with a global warming potential (GWP) of 1430. Do not release R134a into the atmosphere.

Recycling



At the end of the electrical products useful life, it must not be disposed of with household waste.

Recycle at waste facility. Check with your local authority or retailer for local recycling regulations.

Glossary

The following terms are used throughout the manual to describe various functions of Quantum QE.

Distribution system

The distribution system is the system that is used to provide the house with heating through radiators, floor heating and/or fan convectors.

Hydronic unit

The hydronic unit consists of an accumulator tank, pipe connections, electrical connections and the graphical user interface. It provides the house with domestic hot water as well as heating through the distribution system.

Ventilation unit

The ventilation unit is located on top of the heat pump and is connected to the house's ventilation system. It collects energy from the ventilation air and provides it to the hydronic unit to accommodate the comfort demands of the house.

2 BEFORE INSTALLING

Transport

Transport Quantum QE in an upright position. Ensure that the unit is adequately secured so it does not fall during transit.

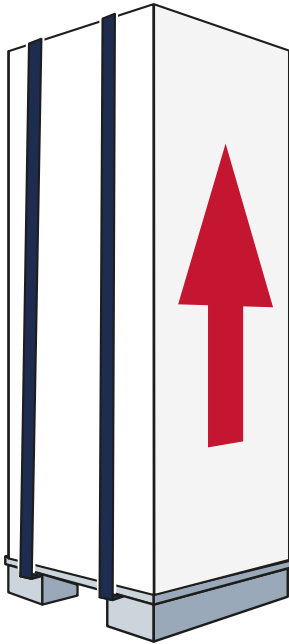

At arrival, ensure that the product was not damaged during transport and that the tilt guard has not been triggered. If QE must be tilted after arrival, always tilt it backwards. If using a trolley or hand truck when moving the heat pump, always have the heat pump standing on the pallet.

NOTE

The tilt guard ensures that the product is not exposed to inappropriate handling during transit. Once the product has been delivered, the tilt guard might be triggered when the product is moved to the installation area.

Installation area

Ensure that the following installation area requirements are fulfilled.

- The foundation withstands the weight of the unit when it is filled.
- The foundation is waterproof and equipped with a floor drain.
- The area always has a temperature between 10 °C and 30 °C.
- The area is not noise sensitive. The heat pump is preferably placed against an outer wall.
- If the heat pump is placed next to a noise sensitive area, for example a bedroom, ensure that the adjacent wall is soundproofed.

TIP

The feet under QE must be adjusted to ensure that the product is stable and positioned in level.

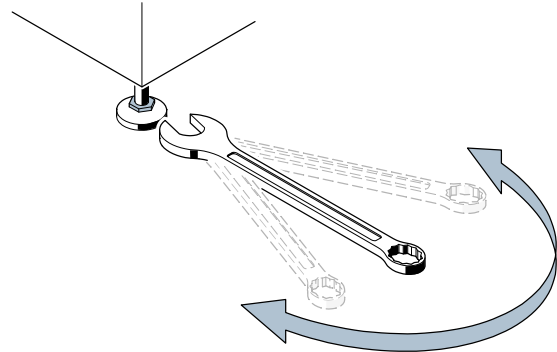

Setup dimensions

CAUTION

A minimum of 800 mm free space must be available in front of the product.

TIP

For ease of ventilation installation, it is recommended that 300 mm of free space is available above the product.

The heat pump must not be installed in close proximity to any interior features or the wall behind. A minimum of 10 mm of clear space should be left behind and next to the heat pump.

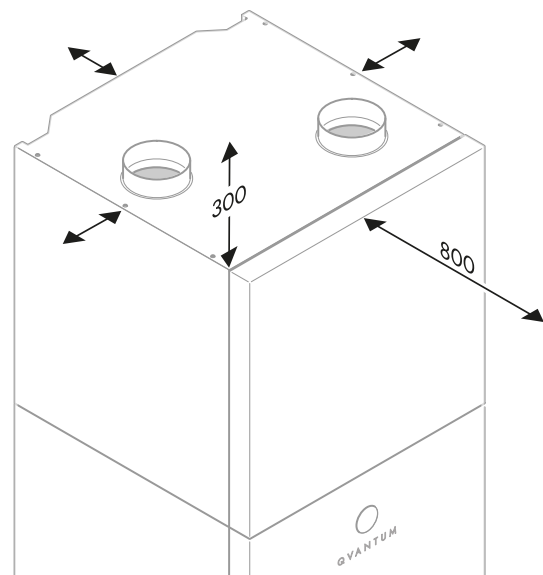

Additional components

Supplied components

The supplied components package contains the following items.

- Two filterball valves
- Outdoor sensor
- Indoor sensor
- Extra air filters
- Vent hose
- 3-pin busbar
- Snap-on ferrite core

Front cover removal

The front covers of the unit is mounted with brackets and clips that are on the frame of the product. The top of the covers rest on the brackets and the bottom of the covers are held in place with the clips.

⚠ CAUTION

The ventilation unit cover must be removed before removing the hydronic unit cover.

1. Carefully pull the bottom of the cover from the unit.
2. Lift the cover upwards.

3. Remove the cover from the unit.

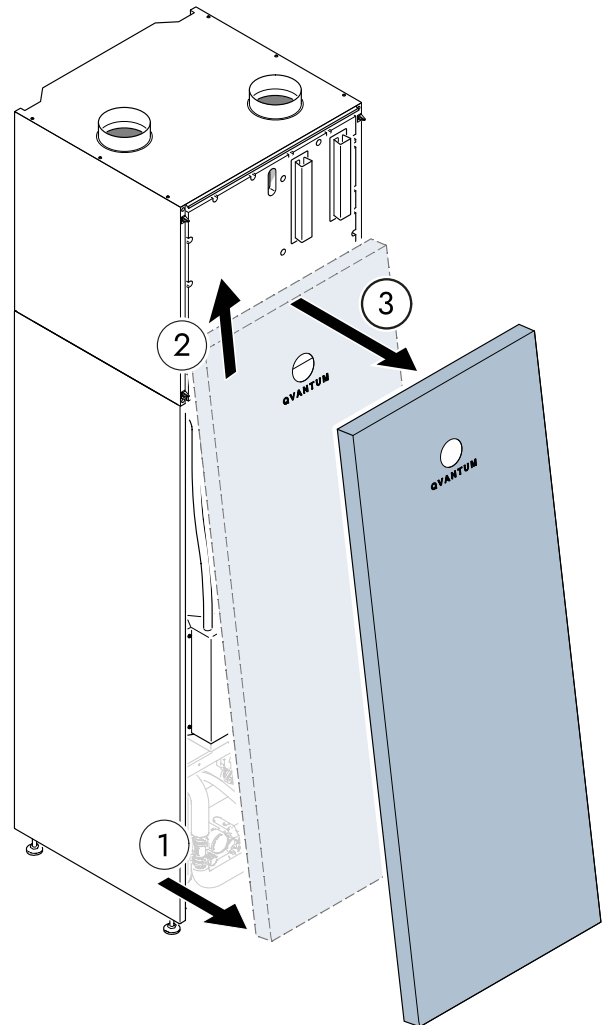
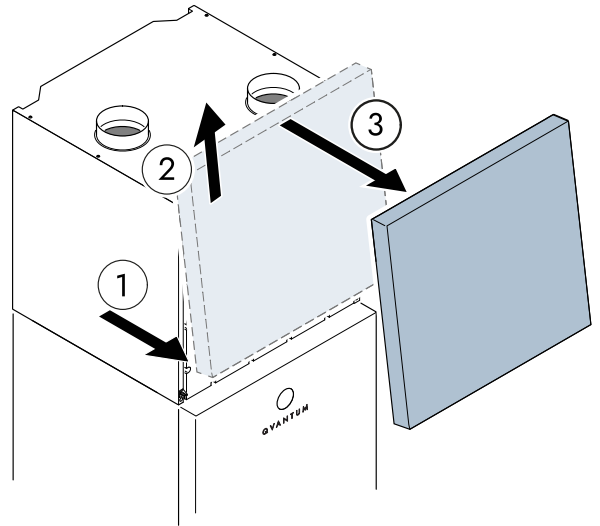

Disconnecting the display unit

The display unit in QE is connected with an ethernet cable on the front cover.

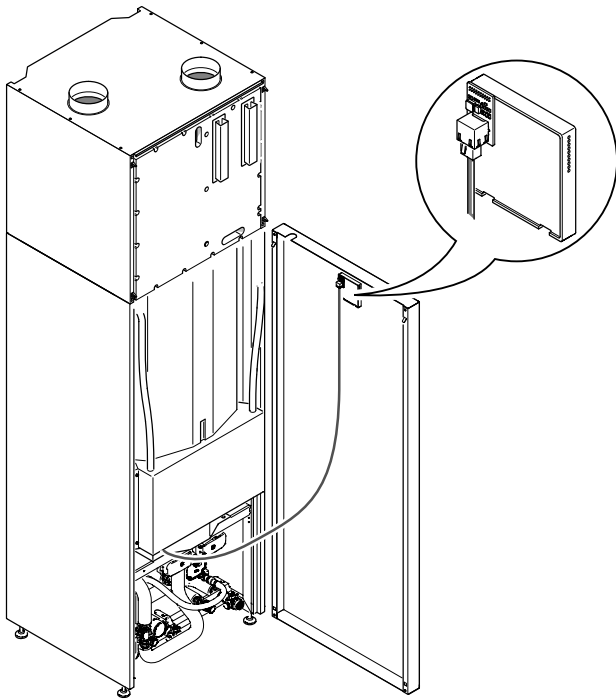

For most installation and servicing tasks, disconnecting the display unit is not necessary. The display cable is long enough for placing the front cover in close proximity to the heat pump.

Remove the ethernet cable from the display unit before moving the front cover too far away from the heat pump.

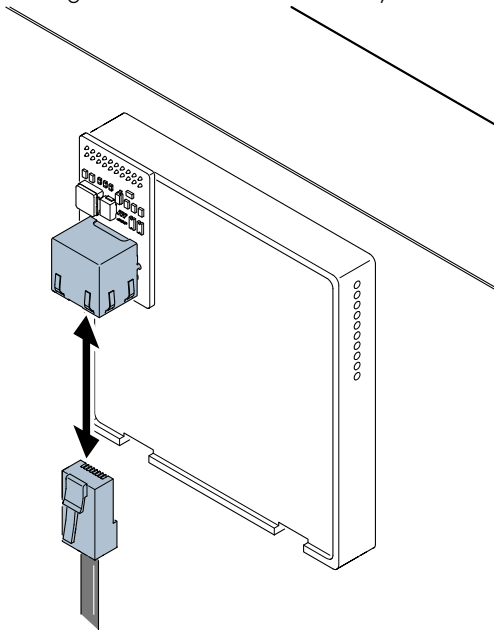

3 COMPONENTS

Overview

Quantum QE consists of two main units; one hydronic unit and one ventilation unit.

The hydronic unit is connected to the facility's piping system through connections that are in the bottom of the hydronic unit. The hydronic unit also contains the heat pump's electrical connections and the user interface.

The ventilation unit is connected to the facility's ventilation system through the ventilation connections on the top of the unit.

Hydronic unit connections

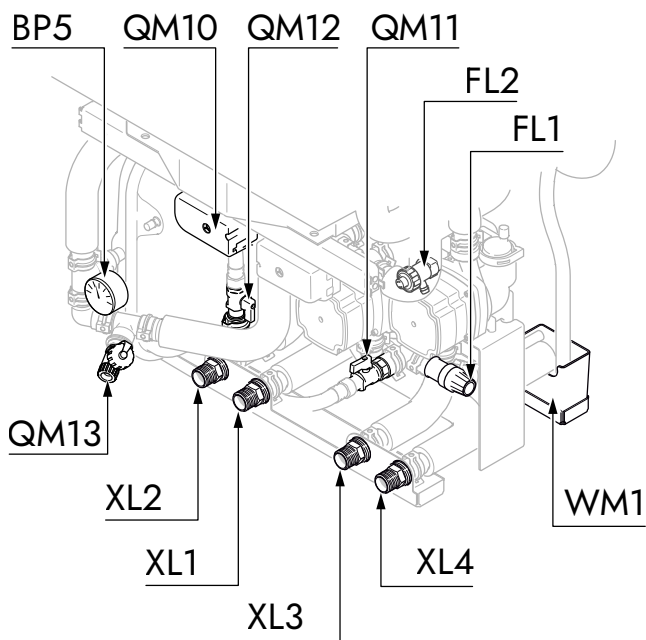

ID ¹	COMPONENT
XL1	Connection distribution system, supply line
XL2	Connection distribution system, return line
XL3	Connection, cold water
XL4	Connection, hot water
QM10	Diverting valve
QM11	Primary refill valve, distribution system
QM12	Secondary refill valve, distribution system
QM13	Drain valve, accumulator tank
FL1	Safety valve, hot water tank
FL2	Safety valve, distribution system
BP5	Pressure gauge
WM1	Overflow cup

¹ Component designations in accordance with IEC 81346.

Ventilation unit

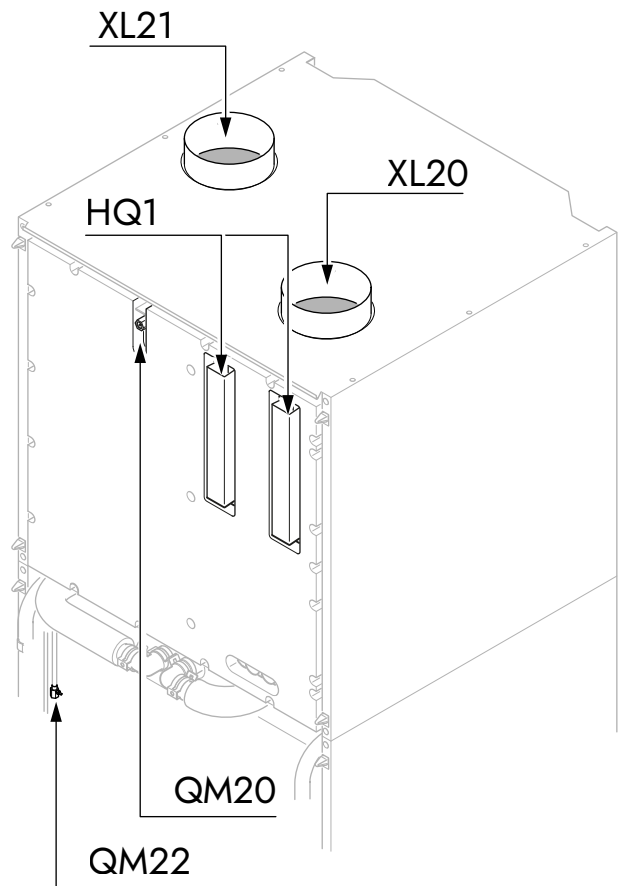

ID ¹	COMPONENT
HQ1	Filters
QM20	Bleed valve, distribution system
QM22	Bleed valve, accumulator tank
XL20	Connection, exhaust air
XL21	Connection, extract air

¹ Component designations in accordance with IEC 81346.

Electrical box

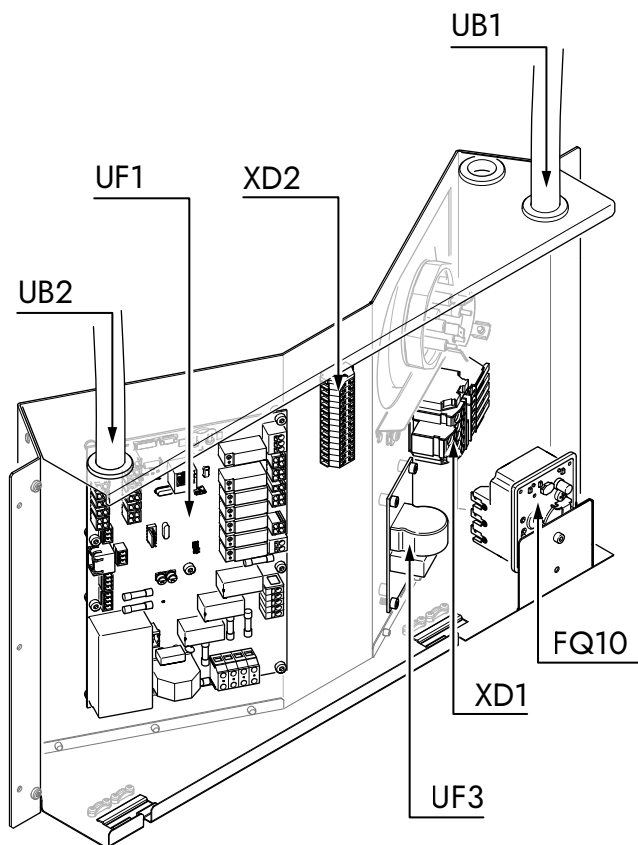

ID ¹	COMPONENT
FQ10	Safety temperature limiter (STL)
UB1	Cable entry, power supply
UB2	Cable entry, communication and sensors
UF1	Main board
UF3	EMC filter card
XD1	Terminal block, power supply
XD2	Terminal block, communication and sensors

¹ Component designations in accordance with IEC 81346.

4 PIPE AND VENTILATION INSTALLATION

Pipe installation, general

NOTE

The pipe installations must be performed in accordance with applicable regulations.

All pipe connections face the front of the heat pump. The radiator system must be correctly adjusted so that the house has a balanced heat transfer.

It is recommended that the maximum allowed supply line temperature does not exceed 55 °C.

CAUTION

The temperature settings must be adjusted to accommodate the highest allowed supply line temperature of the distribution system. Not setting the correct temperatures can cause serious structural damage.

CAUTION

To avoid damage to components, ensure that the piping system is flushed out before connecting the heat pump.

CAUTION

The quality of incoming water must fulfill the requirements declared in EU directive 2020/2184. If the unit is installed where a private well is used it may be necessary to add an extra water filter

Operating principle

The room tempered exhaust air (1) passes through a filter to the heat pumps evaporator (2). As the air passes through the evaporator, the refrigerant evaporates due to its low boiling point. This causes the air to release energy into the refrigerant. The refrigerant is then compressed in the compressor (3) and the temperature rises considerably. The discharge is led to the condenser (4), where the refrigerant releases its energy into the water of the heating system, transforming the refrigerant from gas to liquid.

The refrigerant then passes to the expansion valve (5) where the pressure and temperature are reduced. The circuit is now complete, and the refrigerant passes back through the evaporator.

The heat pump distributes the heat to heating or domestic hot water via a diverting valve (6). If the compressor can not cover the demand in cold weather conditions, the shunt valve (7) starts to open, allowing additional heat stored in the accumulator tank to be distributed. At this stage the temperature in the tank will be maintained by the built in immersion heater (8) which is switched on in stages as needed.

Hot water circulation (9) is installed outside of QE.

NOTE

The following image is a principle picture. The locations of components do not correspond with the actual product.

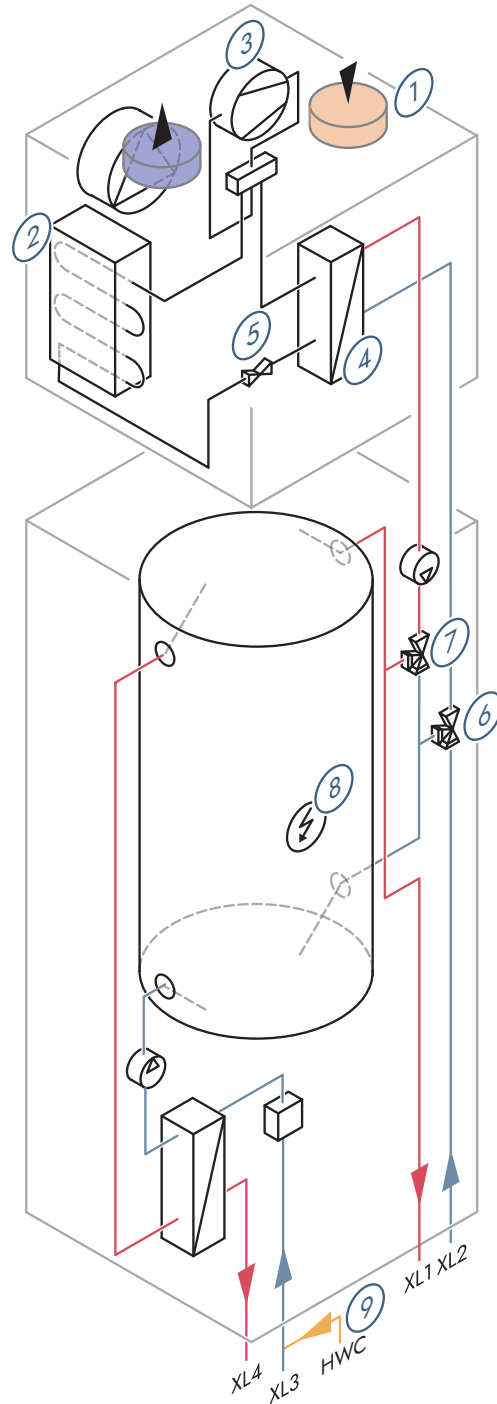

System volume

The expansion vessel in QE has a volume of 12 litres. The vessel has a pre-pressure of 0.5 bar. It is recommended that the height difference between the expansion vessel and the highest installed radiator does not exceed five meters ("Max" in the following image).

The height difference is measured between the center of the expansion vessel and the top-level radiator.



NOTE

If the pre-pressure is too low, the valve on the expansion vessel can be used for refilling of nitrogen. Changing the pre-pressure can affect the expansion vessel's capacity for accommodating the expansion of the water.

At the default pre-pressure of 0.5 bar, the maximum system volume is 200 litres.

Pipe connections

Measurements and dimensions

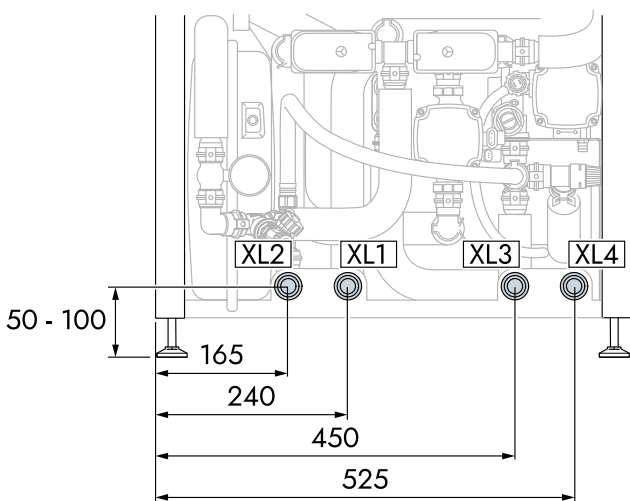

CONNECTION	DIMENSION
XL1, distribution system supply	G20, external thread
XL2, distribution system return	G20, external thread
XL3, cold water	G20, external thread
XL4, hot water	G20, external thread

Installation

NOTE

The pipe connections on QE are forward-facing. For hoses running backward, a 90-degree coupling can be used.

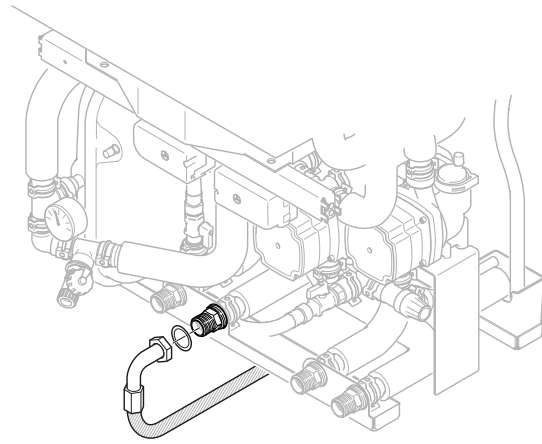

The following image shows a suggested installation solution.

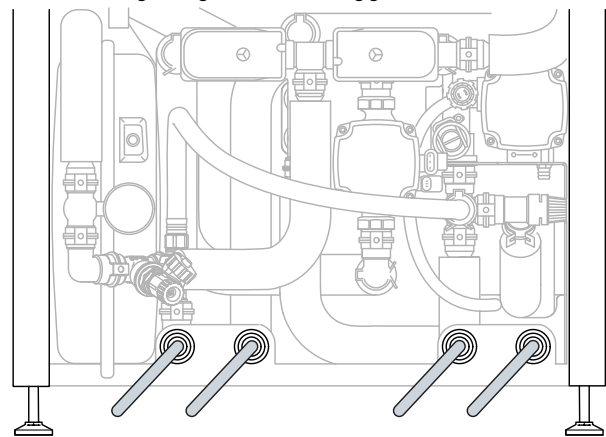

Distribution system

CAUTION

If the water in the distribution system is aggressive or lime-rich, use a water treatment additive to avoid damages to components.

NOTE

Ensure that sufficient system flow passes through the product. Fully opened thermostats helps maintain sufficient system flow and reduce the risk of operational disturbances.

The distribution system is used to accommodate the indoor comfort demands of the property. The QE control system adjusts to the comfort demands through heating suppliers, like for example radiators or floor heating.

- Attach the supplied filterball valve on the distribution system return line before the return connection (XL2).
- Connect the return line from the distribution system to the return connection (XL2).
- Connect the supply line to the distribution system to the supply connection (XL1).

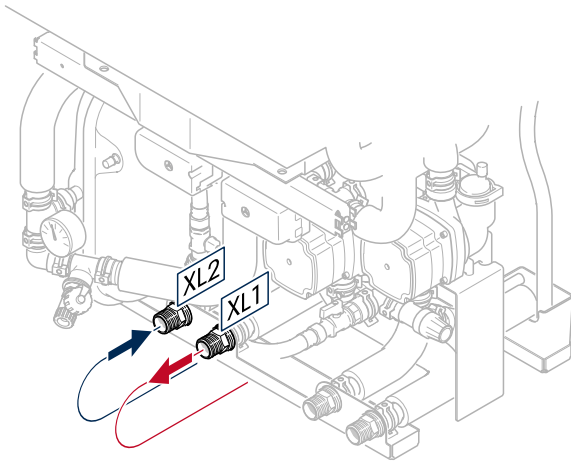

Cold and domestic hot water

- Attach the supplied filterball valve between the cold water main and the cold water connection (XL3).
- Connect the cold water supply to the cold water connection (XL3).
- Connect the domestic hot water system to the hot water connection (XL4).

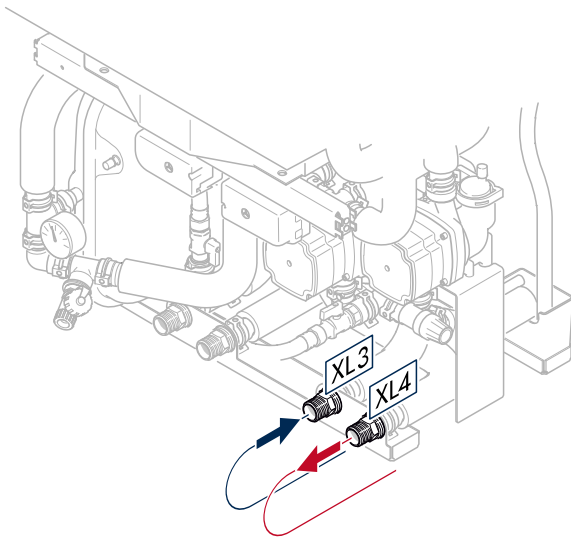

Overflow cup

The overflow cup (WM1) in QE collects condensing water from the ventilation unit and water from the safety valves, if they should release water.

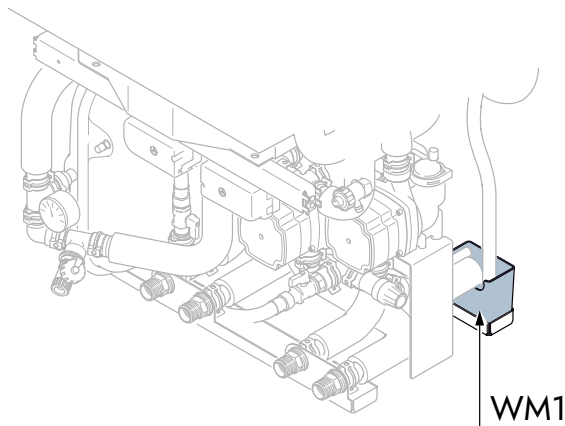

Connect the overflow cup to a floor drain.

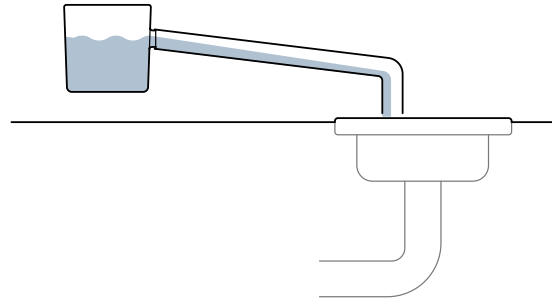

NOTE

The hose from the overflow cup must be installed sloping along its entire length; water must be allowed to flow freely.

Ventilation installation, general

QE is connected to the ventilation ducts through the connections for exhaust air (XL20) and extract air (XL21).

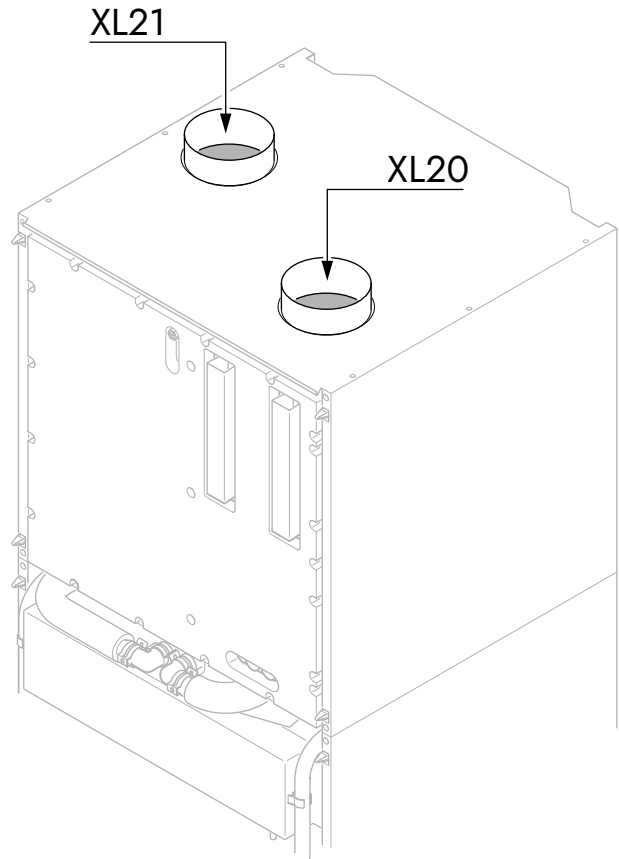

NOTE

The ventilation installation must be performed in accordance with applicable regulations.

- Connect the ventilation with flexible hoses and ensure that they are easily replaceable.
- Ensure that there is enough room to properly maintain the duct.
- Ensure that the ventilation capacity is not decreased due to creasing or tight bends of the hoses.

- Ensure that the duct system has a minimum of class B air tightness.
- Install silencers in the ducts to avoid transportation of fan noise.
- Insulate the exhaust air duct with soundproofing insulation from the top of the heat pump to the inside of the ceiling.
- Insulate the extract air duct along its entire length with diffusion-proof insulation with a thickness equivalent to at least 18 mm cellular rubber foam.

NOTE

Tight bends of the extract air duct can lead to reduced ventilation capacity and increased noise levels.

- Fully seal the condensation insulation at all joints and gaps.
- Connect all exhaust air, except the kitchen fan, so it passes through the heat pump's evaporator.
- Ensure that the distance between the exhaust air device and the kitchen fan is at least 1.5 m.

CAUTION

Do not use a chimney duct for extract air.

TIP

Extra insulation on the ventilation ducts in the installation room can further reduce the noise level.

Measurements and dimensions

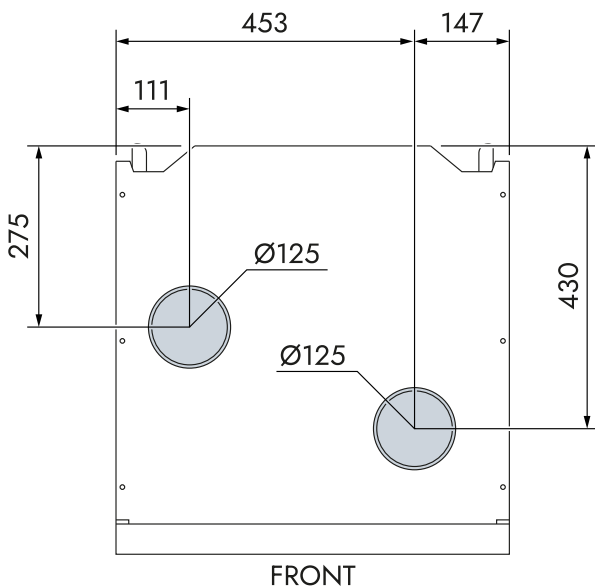

Outside air mixture

General

By applying outdoor air mixture, QE can operate with mixed exhaust air and outside air to have sufficient airflow over the evaporator when in compressor operation. When only exhaust air is used, the heat output may be reduced due to a lack of airflow.

To enable a sufficient flow of outdoor air, that is mixed into the exhaust air, an iris damper (RN1) is installed.

Limitations

WARNING

Outdoor air mixture is only applicable in climate zones with DOT (Dimensioned Outdoor Temperature) above -10° C.

The installation requires installation of an manually adjustable damper for outdoor air.

TIP

Install the required components in such a way that they are easily accessible for maintenance and servicing tasks.

NOTE

The outdoor air temperature is occasionally very low. To avoid damaging QE and/or the house, the damper section and outdoor air duct must be insulated with diffusion proof material. The outdoor air duct must be insulated along its entire length.

Outdoor air operation

The hot air is transferred from the rooms to the heat pump via the house ventilation system. The outdoor air is moved via the outdoor air duct and iris damper (RN1) to the heat pump.

During installation and adjustment, the compressor in QE must be turned off to avoid frost build-up on the evaporator.

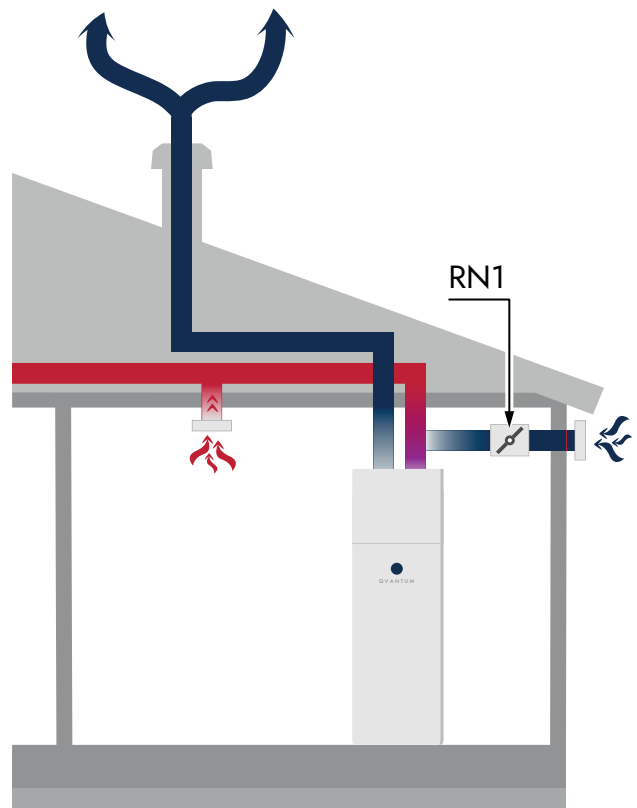

1. Ensure that the iris is closed so that no outdoor air is mixed with the exhaust air.
2. Adjust the ventilation without outdoor air mixture to the pre-calculated ventilation flow.

3. Open the iris damper and increase the fan speed to 100%.
4. Measure the airflow at the reference ventilation grid/damper.
5. Close the iris damper until normal ventilation flow at the reference ventilation grid/damper is obtained.

TIP

If the fan causes unwanted noise, lower the fan speed and open the iris damper until acceptable noise level and sufficient ventilation flow are reached. Opening the iris damper decreases the ventilation flow. Closing the iris damper increases the ventilation flow.

Ventilation flow and adjustments

NOTE

If the ventilation is not adjusted correctly, it may reduce the efficiency of the heat pump. Insufficient air exchange can cause moisture-related damage to the house.

The ventilation flow must be set up in accordance with local regulations. When setting up the ventilation, ensure that the overflow cup is filled with water and that the compressor is turned off.

To ensure that the heat pump works within its operational range, the ventilation flow must be sufficient. The minimum ventilation flow is declared in the following table. The ventilation speed may be set in the start-up guide or at a later stage, through the Qvantum app.

MODEL	MIN. VENTILATION FLOW ¹
QE-4	25 l/s
QE-6	40 l/s

¹ The minimum ventilation flow assumes that the room air temperature is higher than 16 °C.

Proper settings and placement of the exhaust air devices are crucial for reaching sufficient air exchange. Ensure that the heat pump fan is adjusted so that the required air exchange is obtained.

5 ELECTRICAL INSTALLATION

Electrical installation, general

ⓘ WARNING

All electrical connections must be performed by a qualified electrician and in accordance with applicable regulations.

⚠ CAUTION

Do not start the heat pump until it has been filled with water and all electrical connections have been checked. Premature start-up can cause damage to internal components.

- The heat pump must be disconnected before the house wiring is insulation tested.
- Power cables should be placed at least 200 mm from communication and sensor cables.
- It is recommended that the heat pump is installed with a separate residual current device (RCD) with a tripping current of 30 mA.

Cable channels

QE have cable channels on the back of the unit. The channels are made of flexible hoses and are used to reach internal electrical connections.

ID	CONNECTION TYPE
UB1	Power supply
UB2	Communication and external connections

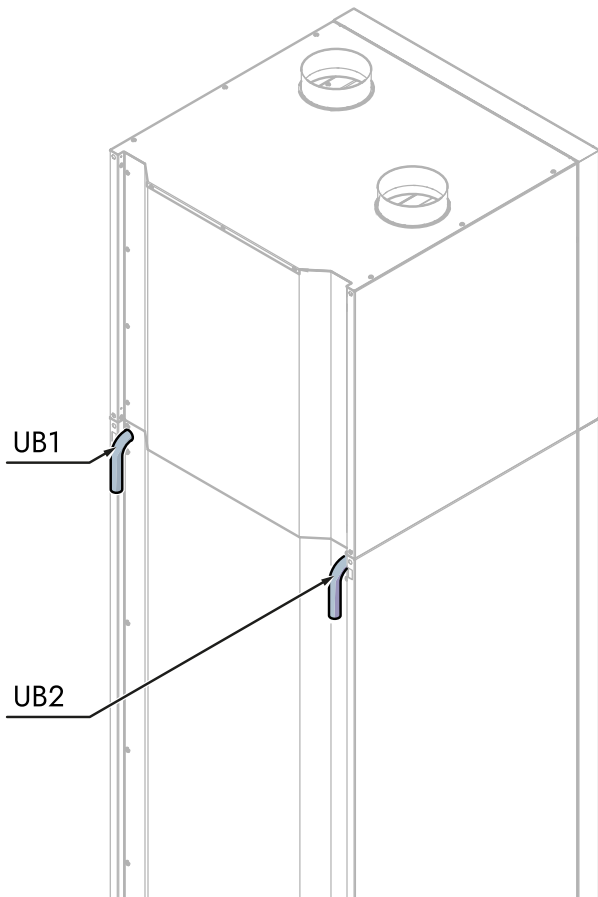

Access

Electrical box

The electrical box is located behind the front cover of the hydronic unit.

Remove the screws of the electrical box cover.

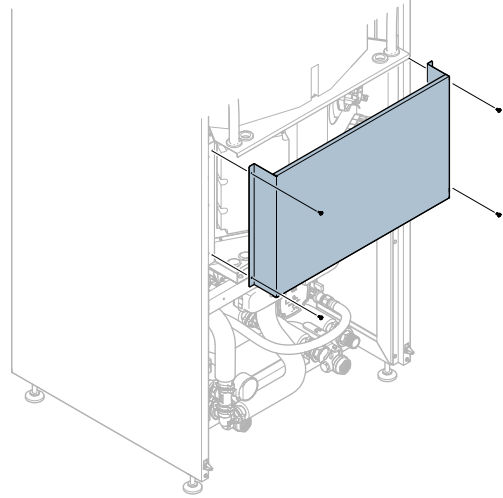

Fuses

The fuses are located on the circuit board (UF1) and the EMC card (UF3) in the electrical box.

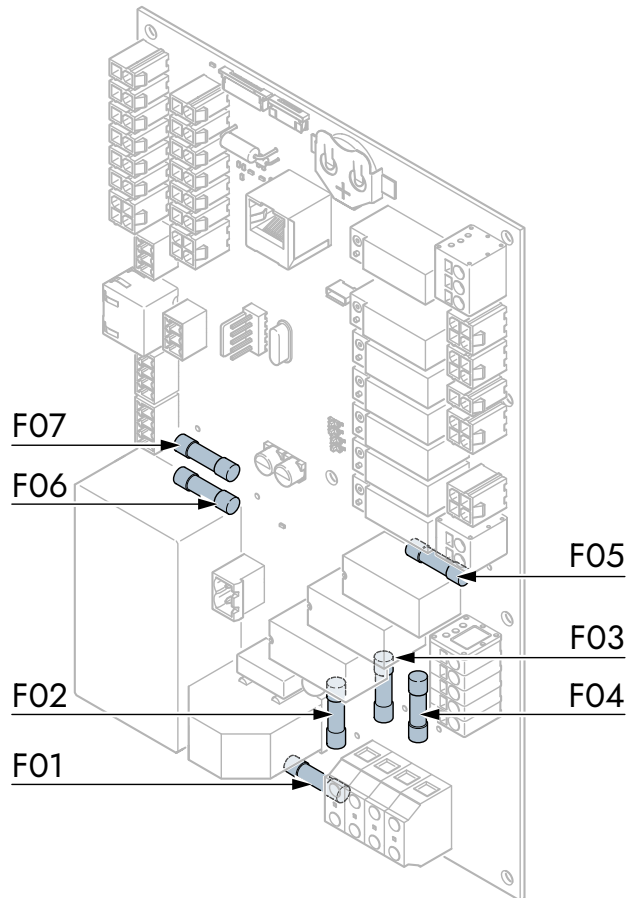

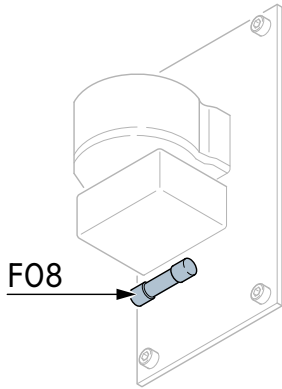

ID ¹	DESTINATION	FUSE SIZE
UF1:F01	Internal 230 V	4A
UF1:F02	Heat element (L1)	10A
UF1:F03	Heat element (L2)	10A
UF1:F04	Heat element (L3)	10A
UF1:F05	External 230 V	2A
UF1:F06	Internal 24 V	630mA
UF1:F07	External 24 V	500mA
UF3:F08	Inverter	12.5A

¹ Component designations in accordance with IEC 81346.

Electrical connections

Power connection

QE can be installed in single or three phase applications.

An isolator switch with a 3mm minimum breaking distance must be used to install QE. Size the minimum cable area in accordance with the fuse rating that is being used. Dimension the fuse size according to the following table.

1X230V	3X400V
35 A (class C)	16 A (class C)

To connect the power supply, open the terminal block lever (1), insert the cable (2) and close the lever (3).

NOTE

The cable strip length should be 13–15mm.

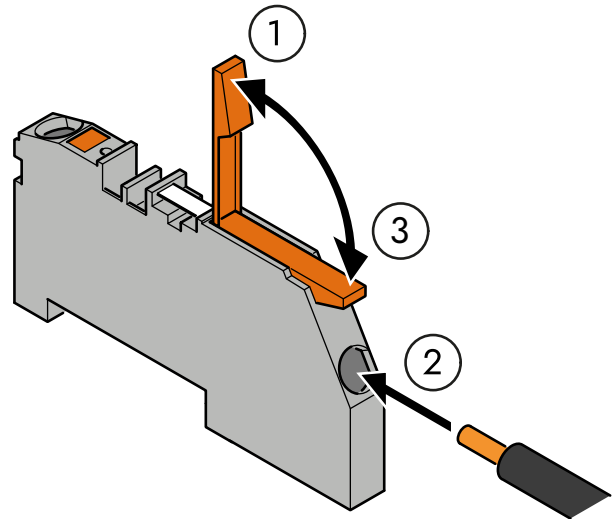

1x230V

For single-phase installations, the supplied 3-pin busbar must be used to bridge the phases on terminal block XD1.

1. Attach the supplied 3-pin busbar so it bridges connections XD1:L1, L2 and L3.

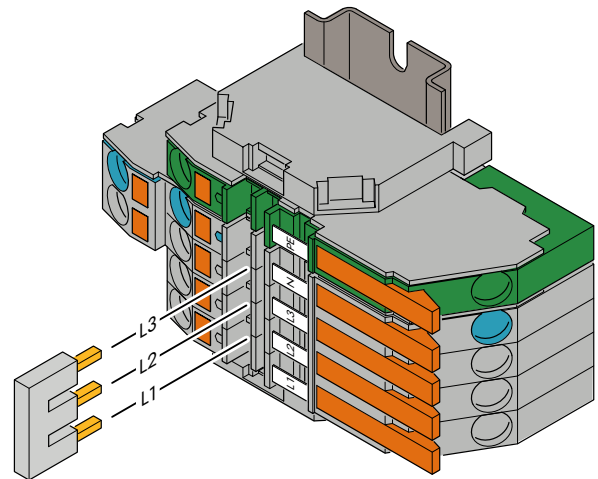

2. Connect the power supply to terminal block XD1.

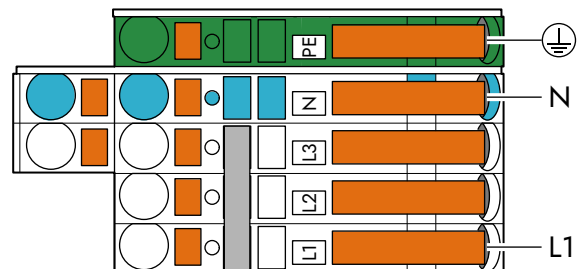

3x400V

NOTE

For three-phase applications, ensure that the house's distribution board is not overloaded. Place the compressor phase (L3) on a low-load group for best performance.

1. Dispose of the supplied 3-pin busbar.

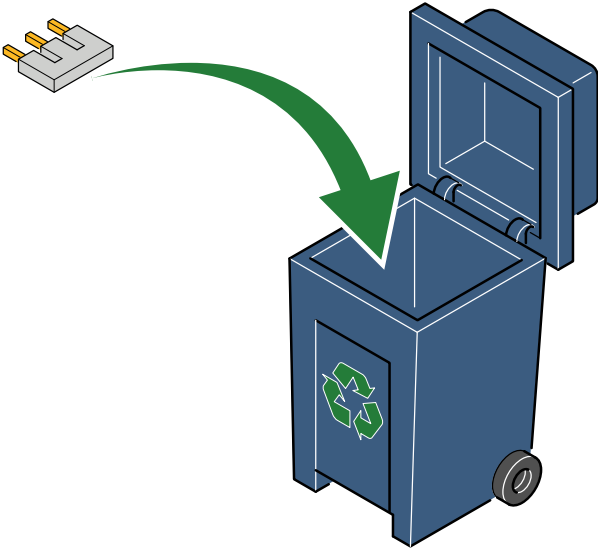

2. Connect the power supply to terminal block XD1.

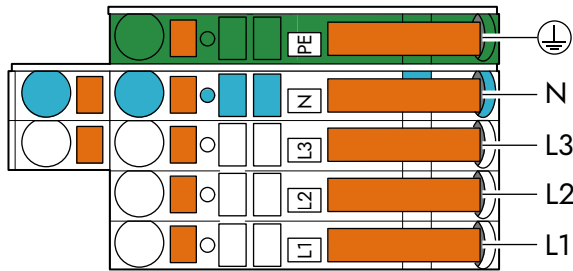

Sensors

The cables are connected to spring loaded terminal blocks on XD2.

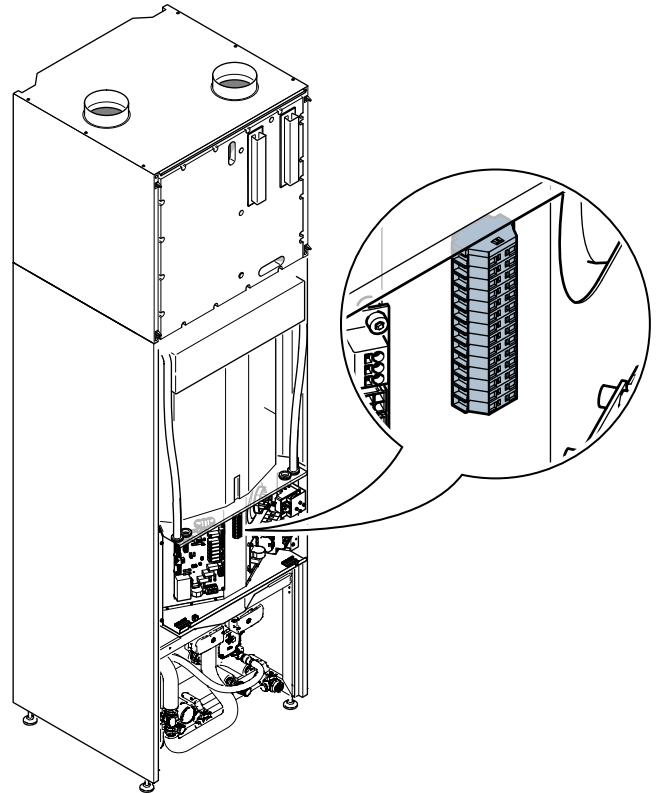

The cable area must be 0.5mm^2 up to 50 m.

Connect the cables by inserting a screwdriver or similar at the top of the terminal block (1). When the spring in the terminal block is open, insert the cable (2).

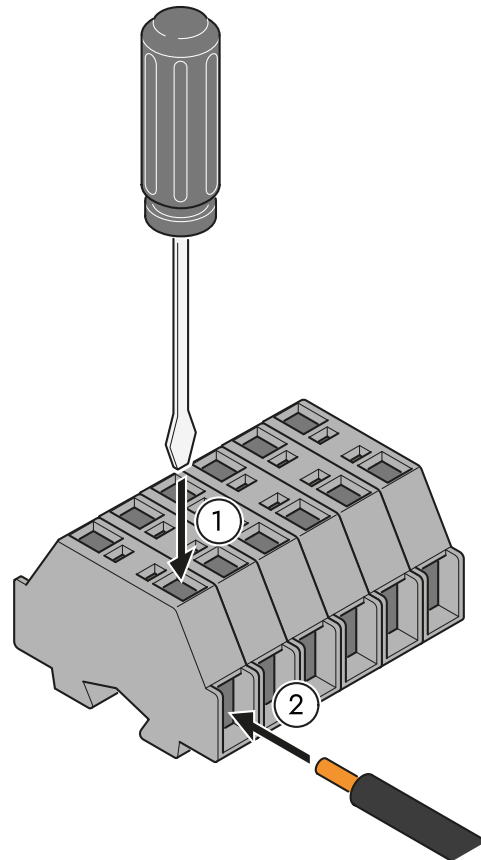

Ferrite

For electrical shielding purposes, all sensor cables should be routed through the supplied ferrite (FE1).

The supplied ferrite (FE1) must be placed outside of QE. It is recommended that the ferrite is mounted at the outlet of the cable channel for external connections (UB2).

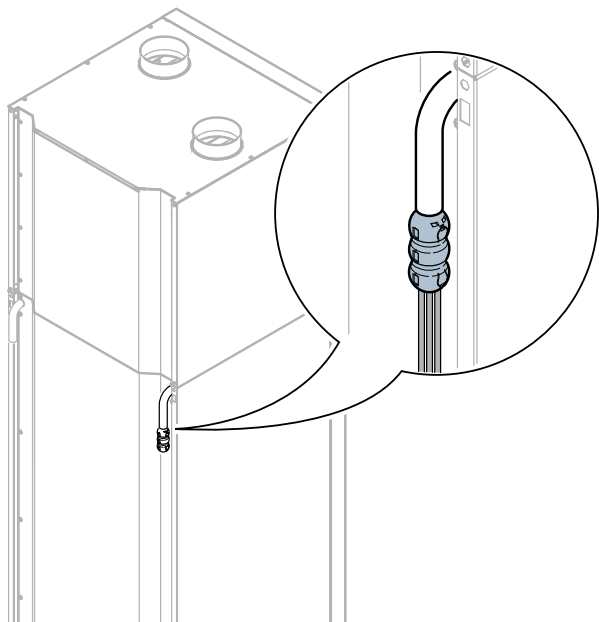

Outdoor temperature sensor

The outdoor temperature sensor (BT1) must be positioned so that it can give an accurate temperature reading. The sensor location should be protected from sun exposure and is preferably installed in a shaded area to the north or northwest.

To prevent condensation in the sensor chamber, seal the tube the cable is running through.

Route the cable through the supplied ferrite (FE1).

Connect the outdoor temperature sensor (BT1) to terminal blocks XD2:1-2.

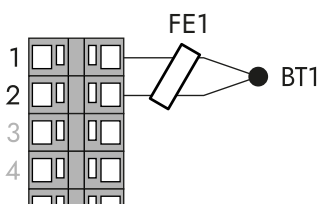

Indoor temperature sensor

The indoor temperature sensor (BT2) enables monitoring and control of the indoor temperature. Installing the indoor sensor is not mandatory, but necessary for reading the indoor temperature.

The sensor should be positioned so that it can give an accurate temperature reading, about 1.5 meters above the floor. Avoid placing it near heaters, radiators, windows, front doors, or anything else comparable. It must not be covered, exposed to air currents, or exposed to heat sources.

Route the cable through the supplied ferrite (FE1).

Connect the indoor temperature sensor (BT2) to terminal blocks XD2:3-4.

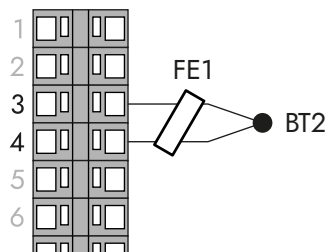

Safety temperature limiter

Quantum QE is equipped with a safety temperature limiter that is behind the cover of the electrical box. The safety temperature limiter will stop the power to the immersion heater if the temperature becomes too high.

⚠ CAUTION

Verify that the safety temperature limiter has not been triggered prior to installation.

A manual reset is required if the safety temperature limiter has been triggered. By pushing the button that can be accessed through a hole in the electrical box cover, the limiter is reset.

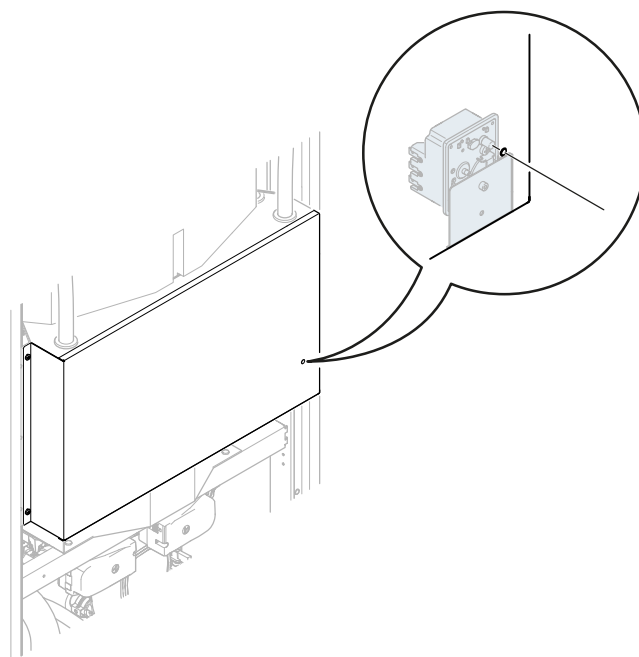

6 COMMISSIONING

Quantum app

To properly set up Quantum QE, install the Quantum app and follow the in-app instructions.

The app contains an installation checklist that helps you control all parts of the installation before starting the heat pump for the first time.

At first start-up of the unit, the app helps you set up the machine.

Preparations

1. Ensure that the heat pump is turned off.
2. Ensure that the filling valves are entirely closed.

NOTE

The filling valves must be closed during normal operation.

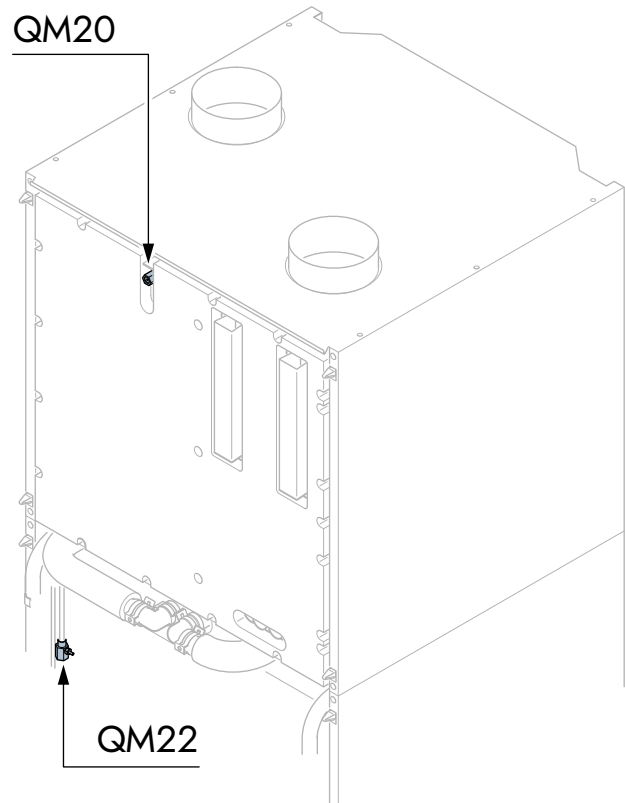
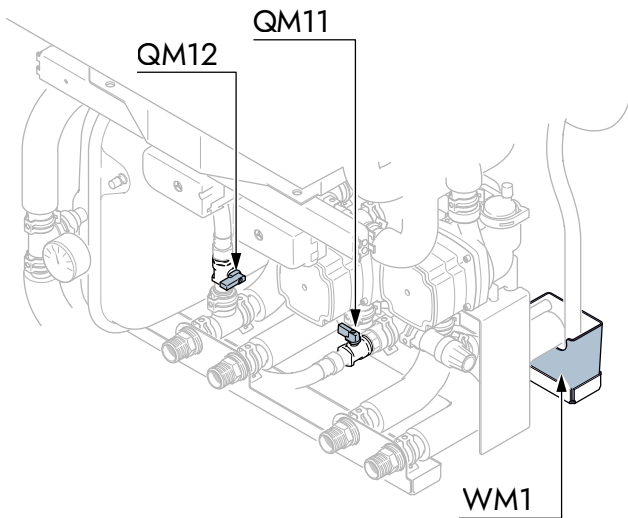

Filling

Water heater

1. Ensure that the filterball valve that is connected to the cold water connection (XL3) is open.
2. Open one of the facility's hot water taps.
3. Open the facility's main cold water valve.

When no more air comes from the hot water tap, close the tap.

Distribution system

Before opening bleed valves on QE, attach a hose to the affected valve.

1. Open the bleed valves for the distribution system (QM20) and the accumulator tank (QM22)
2. Ensure that the hose between the filling valves is securely attached.
3. Open the filling valves (QM11 and QM12)
The distribution system and accumulator tank will be filled with water.
4. Wait for the distribution system to be completely purged and close the bleed valve (QM20).

The system pressure will increase and affect the pressure gauge. When the system pressure reaches a predefined threshold, the safety valve releases water.

5. Wait for the accumulator tank to be completely purged and close the bleed valve (QM22).
6. Close the filling valves.

7. Reduce the distribution system pressure to approximately 1 - 1.5 bar.
 - a) Reduce the distribution system pressure by opening the bleed valves or the safety valve.
8. Ensure that there is water in the overflow cup.
9. Start up the heat pump.
 - a) Allow the heat pump to run for one heating cycle and one hot water cycle.
10. Ensure that the heat pump provides room heating and hot water.
11. Open the bleed valves.
12. Wait for the bleed valves to be completely purged.
13. Close the bleed valves.

Filling the overflow cup

Check if the overflow cup (WM1) must be refilled with water.

1. Carefully open the safety valve for the hot water. The overflow cup will slowly fill with water.
2. Close the safety valve for the hot water when the overflow cup has been filled.

Venting

Distribution system

1. Turn off the heat pump and wait for at least 30 seconds.
2. Turn off the power supply to the heat pump.
3. Deair the heat pump by opening the bleed valves.
4. Refill and bleed the distribution system until all air is removed and adequate system pressure is reached.

First start-up

⚠ CAUTION

Before starting the heat pump, ensure that there is no frozen water in the system.

⚠ CAUTION

Before starting the heat pump, ensure that there is water in the distribution system.

1. Turn on the heat pump.
2. Set up the heat pump by following the steps shown in the display unit.

To adjust the settings after the first start-up, use the display unit or the Quantum app. The most common settings are available in both the display unit and the app. To access more advanced settings, the app must be used.

If the property is cool at commissioning, the internal additional heating might be activated to help the compressor satisfy the heating demand.

Setting up the ventilation

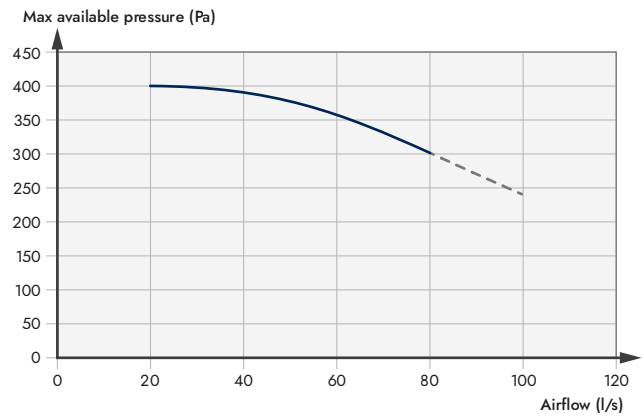

NOTE

If the fan speed is set to 0, QE will run with only electrical addition.

Pump speed

The speed of the heating medium pump is adjusted through the Quantum app.

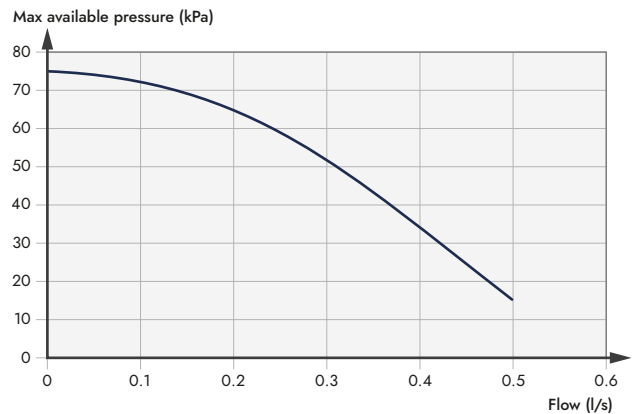

7 USER INTERFACE

Introduction

Quantum QE is equipped with a user friendly touchscreen display. Through the display, the most necessary settings can be accessed and adjusted.

More settings are available through the Quantum app.

Using the display unit

Use the arrow buttons (1) on the sides of the interface to access the different pages in the display unit.

For display pages with settings, use the slider (2) at the bottom of the display to adjust the settings. The default value for the setting is shown with a black line within the slider (3).

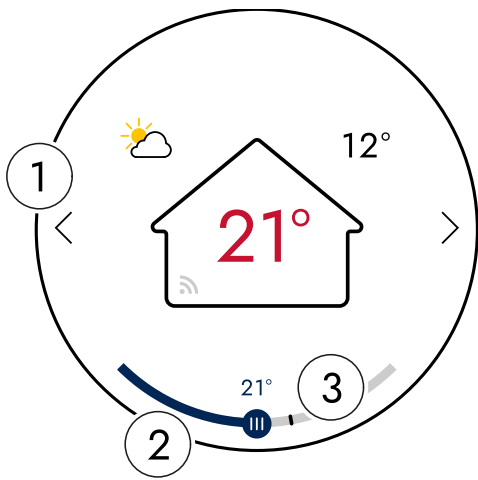

Swipe upwards and downwards to access all content on display pages that contain multiple lines of information

Display pages

Home page

The home page is used to deliver comfort-related information as well as modify the indoor temperature.

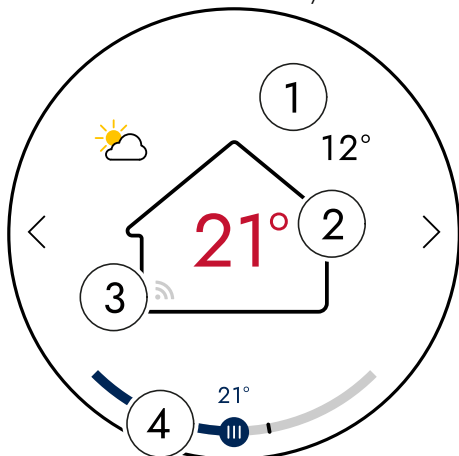

1. Outdoor temperature, as read by the outdoor temperature sensor.
2. Current indoor temperature. Requires installation of an indoor temperature sensor.
3. Symbol showing the status of the Wi-Fi connection.
4. Slider for adjusting the indoor temperature. The value above the slider shows the set value.

Domestic hot water

The page for domestic hot water is used to deliver information about the hot water production as well as modify the hot water temperature.

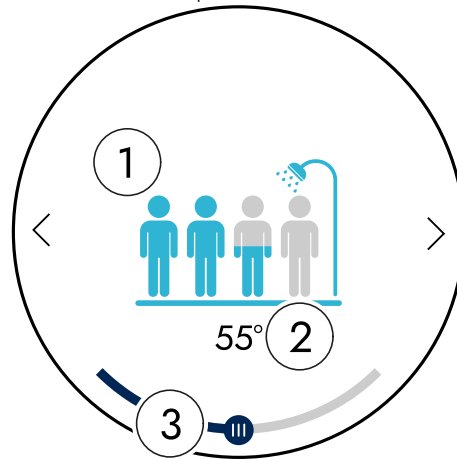

1. Indicator that shows the amount of remaining hot water. When the set temperature is reached, all characters are colored blue. The number of characters depend on the requested hot water temperature.
2. Set value for the domestic hot water.
3. Slider for adjusting the hot water temperature.

Comfort and scheduling

The comfort and scheduling page is used to activate and control functions that accommodate needs that are outside of the heat pump's default operational modes.



Extra ventilation boosts the ventilation to reach additional air exchange. This is useful when, for example, the house is more crowded than usual.

Additional hot water increases the hot water production for instances where additional hot water is desired.

Away mode is a scheduling function that is useful when leaving the house for longer periods of time. When the away mode is activated, the heat pump lowers the indoor temperature and the hot water production.

Extra settings

The settings page has a number of subpages that are used to retrieve product information, change display options, and configure heat pump performance.

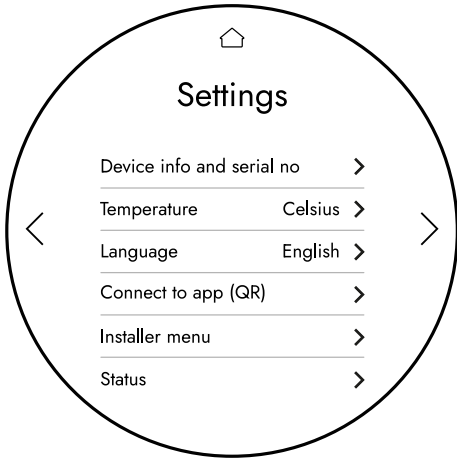

8 SERVICE

General

⚠ CAUTION

Maintenance and servicing must be performed by persons with sufficient knowledge about the task.

Maintenance

👉 NOTE

The end user must be informed about necessary maintenance actions.

Floor drain

Check the overflow cup and any floor drains for obstructions on a regular basis; water must be allowed to flow freely. If required, clean.

Filter change

The filters in QE must be replaced on a regular basis. The filter cassettes are accessed by removing the front cover of the ventilation unit. Replace both filters at the same time.

Order individual filters by visiting www.quantum.com.

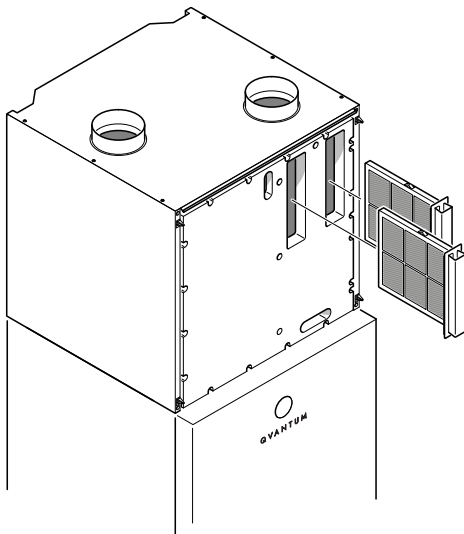

1. Pull the back of the fixing plate upwards.
2. Remove the fixing plate from the filter cassette.

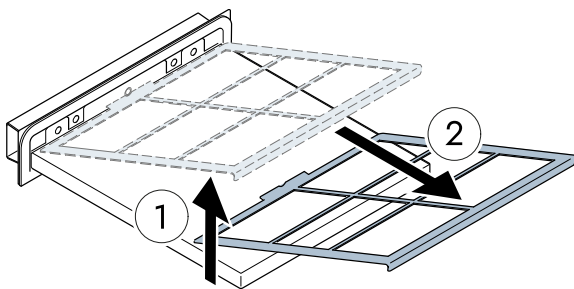

3. Remove the used filter and replace it.

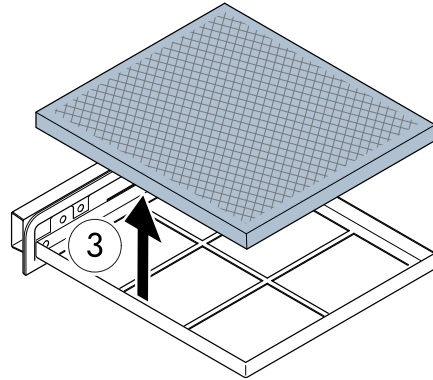

When remounting the fixing plate on the filter cassette, align the flap of the plate with the slot in the cassette.

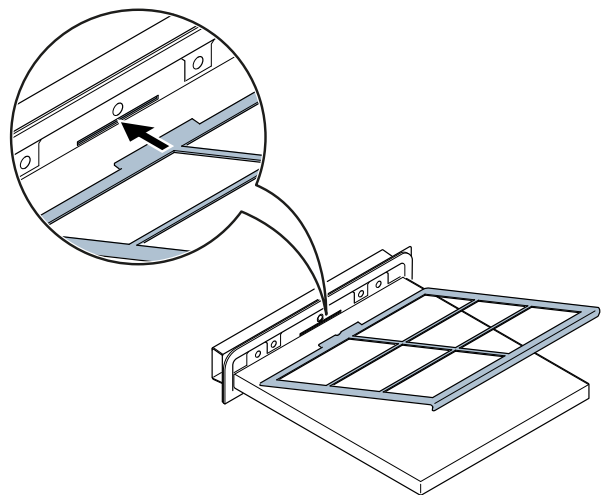

Overflow cup

The overflow cup in the heat pump must be cleaned regularly so that water can run unhindered.

1. Turn off the heat pump.
2. Clean the overflow cup.
3. Turn on the heat pump.

Ensure that water runs freely through the overflow cup.

Service actions

Draining the product

In case of component changes or if the heat pump must be moved, it might be necessary to drain the product of water. Emptying the accumulator tank is done through the tank drain connection (QM13). If necessary, rotate the drain valve by pulling it upwards or downwards.

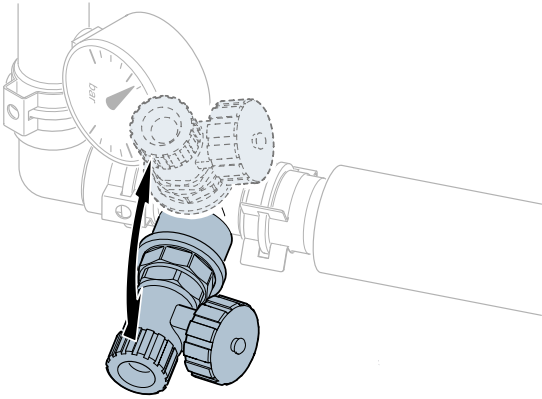

⚠ CAUTION

Turn off the heat pump before draining the accumulator tank.

1. Remove the cap from the drain connection.

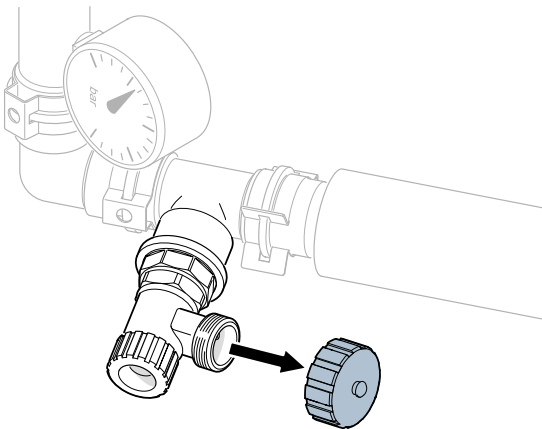

2. Attach a garden hose tap connector (1").

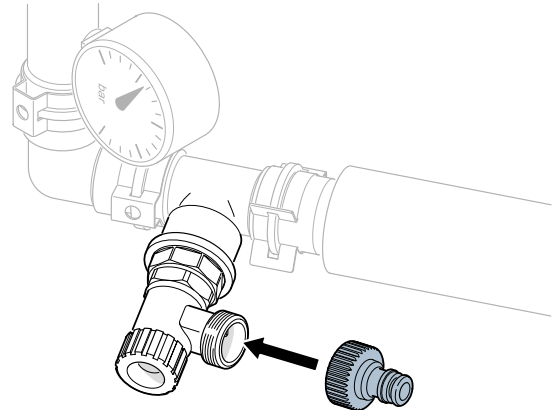

3. Attach a hose with a connector to the tap connector.

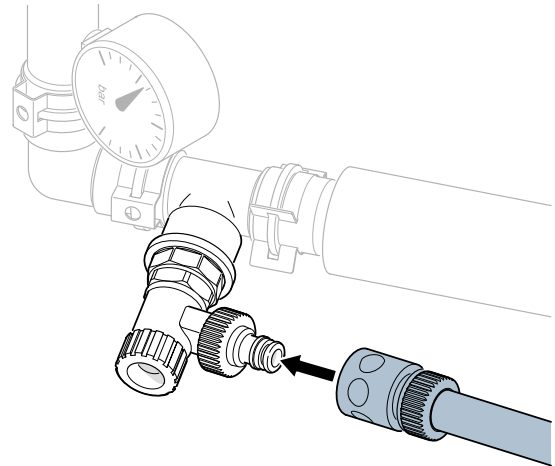

4. Open the drain connection by turning in counter-clockwise.

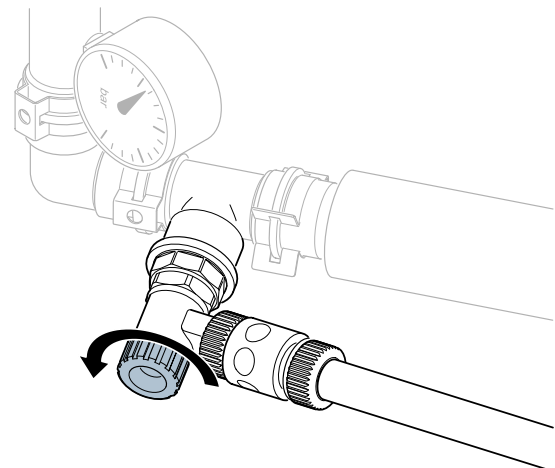

5. Open the bleed valve (QM22) for the accumulator tank.

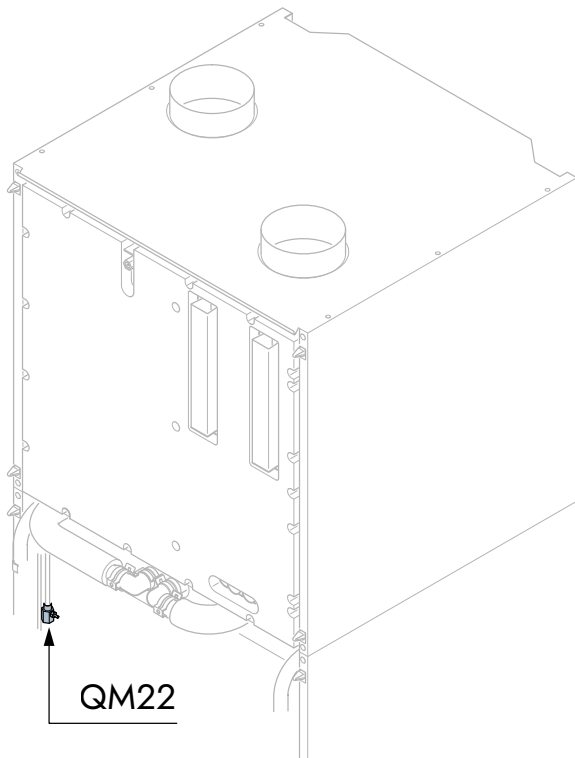

c) Remove the actuator (3).

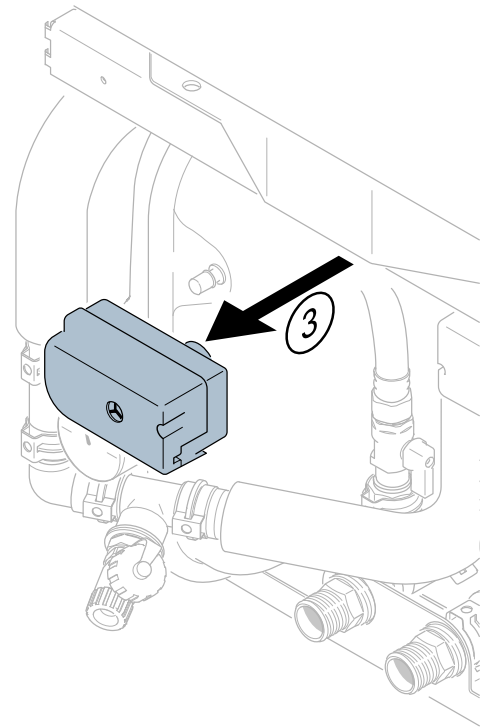

6. Remove the actuator from the diverging valve (QM10).

- a) Pull the quick release lock (1) away from the actuator outlet.
- b) Press the quick release ring (2).

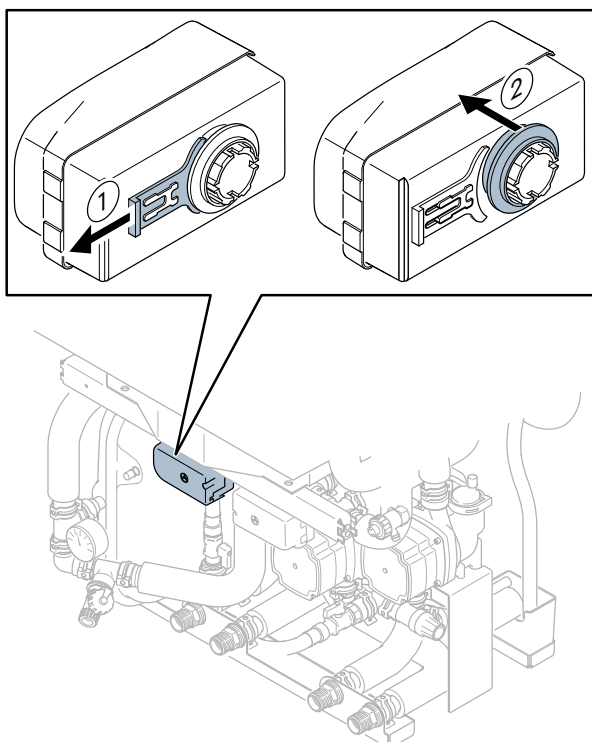

7. Turn the valve axle counter-clockwise (4) until the water starts flowing.

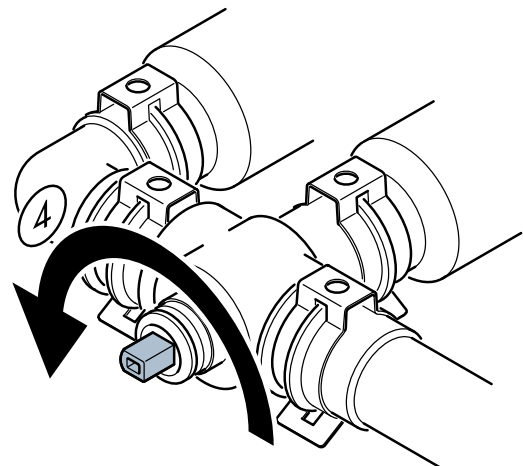

When water stops coming from the hose, restore the product to its original state.

- Close the drain connection
- Close the bleed valve
- Restore the diverging valve axle to the original position
- Reattach the actuator
- Remove the hose connectors
- Reattach the cap.

9 COMFORT DISTURBANCE

Troubleshooting

Before troubleshooting

If the system does not inform about an active fault, check the following components before troubleshooting.

WARNING

The incoming supply electricity must be isolated at the safety switch by or under the supervision of a trained electrician in the event that corrective action is needed to address faults that call for work inside screwed hatches.

- Power supply.
- Group and main fuses of the property.
- Residual current device (RCD).
- Internal fuses (F01–F08).
- Safety temperature limiter (FQ10).

Low room temperature during heating

The room temperature is undesirably low when a heating demand is active.

Closed thermostats

- Ensure that the thermostats are fully open. Keep in mind that individual thermostats can be turned down if a certain space needs to be cooler than the set target temperature.

Incorrect operational mode

- If operational mode **Auto** is active, set a higher value for setting **Stop heating**.
- If operational mode **Manual** is active, select **Heating**.
 - a) If selecting **Heating** is insufficient, enable setting **Allow additional heat**.

Too low target settings for automatic heat control

- Set a higher value for the offset heating curve.
 - a) If the room temperature is only insufficient in cold weather, increase the **Heating curve** setting with one step.

Wrong prioritisation set for heating

- Increase the time for heating prioritisation. Increasing the time for heating prioritisation reduces the time for hot water production, which can give insufficient hot water production.

Operational mode **Extra** combined with increased hot water consumption

- Set operational mode **Eco** or **Normal**.

Vacation mode is active

- Turn off **Vacation mode** through the Quantum app.

Room heating is controlled by external input

- Check external switches.

Heating medium pump(s) have stopped

- Check speed settings for circulation pumps.

Air in the distribution system

- Purge the distribution system.

Shut-off valve for heating medium supply is closed

- Open the shut-off valve for heating medium supply.

Insufficient value set for electrical addition

- Use the Quantum app and increase the setting for **Max electrical addition**.

Incorrect setting for max installed electrical power

- If possible, use the Quantum app and increase the setting for **Max installed electrical power**.

High room temperature during heating

The room temperature is undesirably high when a heating demand is active.

Too high target settings for automatic heat control

- Set a lower value for the offset heating curve.
 - a) If the room temperature is only too high in cold weather, decrease the **Heating curve** setting with one step.

Heating is controlled by external input

- Check external switches.

Insufficient hot water production

Lack of domestic hot water.

Faulty pipe installation

- Verify that the pipes for the hot and cold water connections are installed correctly.

The filling valve for the hydronic unit is closed

- Verify that the filling valve is open.

The external mixing valve is set too low

- If present, verify that the mixing valve is set correctly.

Increased hot water consumption

- Wait until the domestic hot water reaches a sufficient temperature. The hot water production can be temporarily increased by activating operational mode **Extra** for hot water capacity.

Too low target temperature for hot water production

- Increase the target temperature for hot water production.

Wrong prioritisation set for hot water production

- Increase the time for hot water prioritisation. Increasing the time for hot water prioritisation reduces the time for heating production, which can give uneven or too low room temperatures.

Insufficient ventilation

The ventilation is insufficient or missing.

Blocked filter

- Clean or replace the filters.

Ventilation set-up not done

- Perform ventilation adjustments.

Reduced air flow at exhaust air valve

- Clean exhaust air device.
- Check adjustments of exhaust air device.

Reduced fan speed

- Change setting **Fan speed** to **Normal**.

Fan speed is controlled by external input

- Check external switches.

Abnormal ventilation noise

Blocked filter

- Clean or replace the filters.

Ventilation set-up not done

- Perform ventilation adjustments.

Forced fan speed

- Change setting **Fan speed** to **Normal**.

Fan speed is controlled by external input

- Check external switches.

Low system pressure

Insufficient amount of water in the heating system

- Refill the water in the heating system.

Compressor not starting

An alarm is active

- Follow the instructions that are shown on the display or in the Quantum app.

No comfort demand is active

- Neither heating or hot water production is requested.

The compressor cannot start because of temperature limitations

- Wait until the heat pump is within its operational temperature range.

Too little time has passed since last compressor start

- Wait until at least 30 minutes has passed.
 - a) Check if the compressor has started.

10 TECHNICAL SPECIFICATIONS

Dimensions and installation coordinates

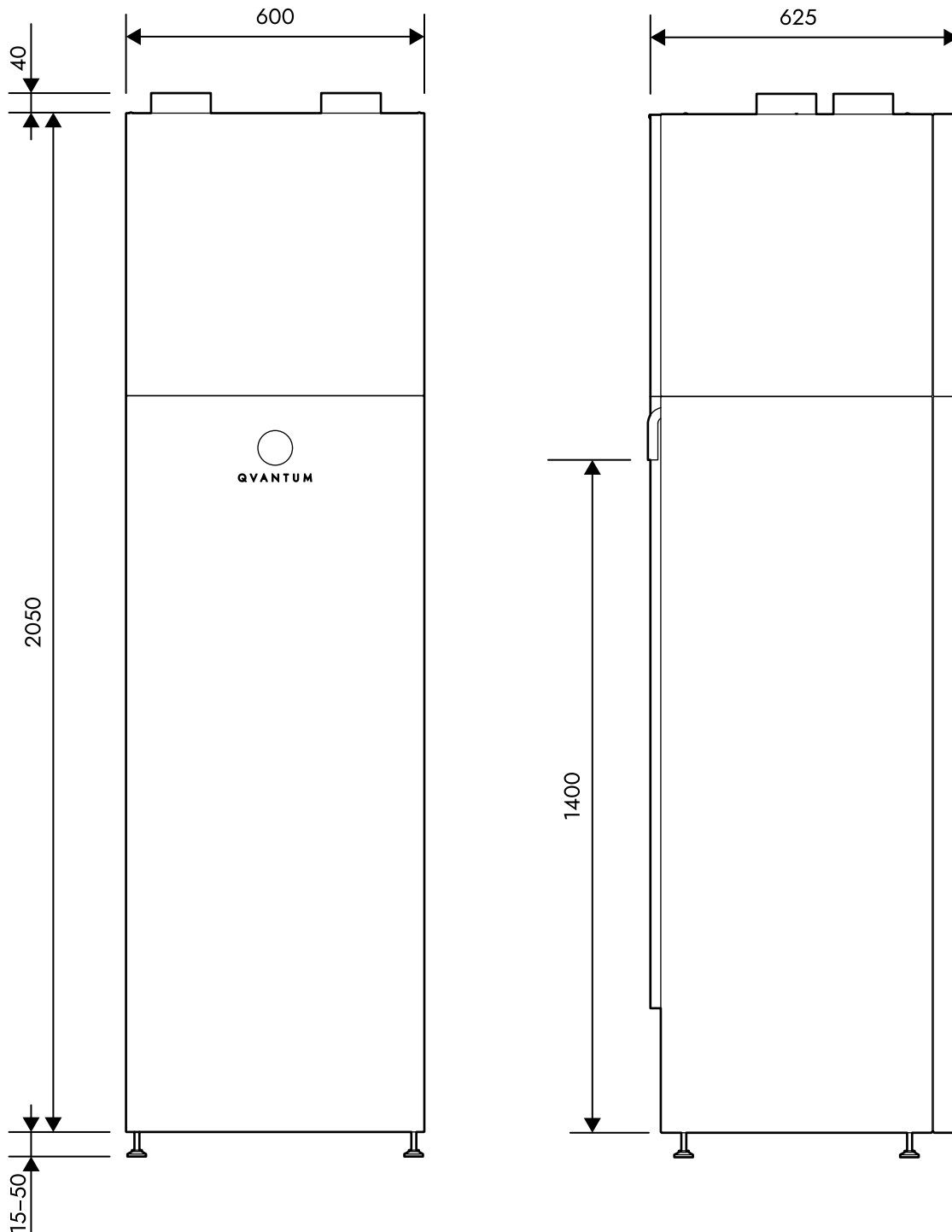

Technical data

MODEL		QE-4	QE-6
Energy efficiency, average climate			
The product's efficiency class room heating, average climate 35 / 55 °C			A++ / A++
The system's efficiency class room heating, average climate 35 / 55 °C			A++ / A++
Declared tap profile/efficiency class hot water heating			A+ / XL
Output data (EN14825)			
Nominal heating output ($P_{designh}$)	kW	4	6

MODEL		QE-4	QE-6
SCOP average climate, 35 °C / 55 °C		3.8 / 3.3	3.8 / 3.3
Refrigerant circuit			
Type of refrigerant (GWP)		R134a (1430)	
CO ₂ equivalent	kg	1573	1716
Refrigerant quantity	kg	1.1	1.25
Cut-out value pressostat HP	MPa / bar	2.45 / 24.5	
Heating medium circuit			
Operating pressure, safety valve	MPa / bar	0.3 / 3	
Max recommended temperature, supply line	°C	58	
Minimum flow	l/s	0.08	0.15
Operational range	°C	25 - 60	
Accumulator tank			
Tank volume	l	175	
Max pressure, accumulator tank	MPa / bar	0.3 / 3	
Operating pressure, safety valve	MPa / bar	0.3 / 3	
Ventilation			
Recommended air flow	l/s	25 - 50	40 - 70
Operational range, exhaust air	°C	15 - 35	
Hot water capacity			
Amount of domestic hot water (40 °C) EN16147 ¹	l	253	
Electrical data			
Rated voltage	V	400V 3N ~ 50Hz / 230V 1N ~ 50Hz	
Max power immersion heater	kW	5.0 (1+2+2)	
Recommended fuse, 3x400V / 1x230V	A	16 / 35	
Enclosure class		IP 21	
Sound data			
Sound power level (L _{W(A)})EN12102	dB(A)	40 - 54	
Sound pressure level in installation area (L _{P(A)})	dB(A)	36 - 50	
Connection dimensions			
Distribution system, external thread ø		G20	
Cold water, external thread ø		G20	
Hot water, external thread ø		G20	
Ventilation ø	mm	125	
Weight and dimensions			
Weight, empty / filled	kg	160 / 335	170 / 345
W x D x H ²	mm	600 x 619 x 2050	
Required ceiling height	mm	2170	
Misc.			
Part no.		30100	30101

¹ At tap flow rate 12 l/min

² Height without ventilation connections

Energy labelling

Information sheet

SUPPLIER		QVANTUM	QVANTUM
MODEL		QE-4	QE-6
Temperature application	°C	35 / 55	35 / 55
Declared load profile for water heating		XL	XL
Seasonal space heating energy efficiency class, average climate		A++ / A++	A++ / A++
Water heating energy efficiency class, average climate		A+	A+
Rated heat output (P _{design,h}), average climate	kW	4 / 4	6 / 6
Annual energy consumption space heating, average climate	kWh	2166 / 2505	3211 / 3671
Annual energy consumption water heating, average climate	kWh	1116	1116
Seasonal space heating energy efficiency, average climate	%	150 / 129	151 / 132
Water heating energy efficiency, average climate	%	124	124
Sound power level L _{WA} indoors	dB	42	42

Data for energy efficiency of the package

MODEL		QE-4	QE-6
Temperature application	°C	35 / 55	35 / 55
Controller, class		IV	IV
Controller, contribution to efficiency	%	4	4
Seasonal space heating energy efficiency of the package, average climate	%	154 / 133	155 / 136
Seasonal space heating energy efficiency class of the package, average climate		A++ / A++	A++ / A++

Technical documentation

QE-4

MODEL		QE-4					
Type of heat pump		<input type="checkbox"/> Air-water <input checked="" type="checkbox"/> Exhaust-water <input type="checkbox"/> Brine-water <input type="checkbox"/> Water-water					
Low-temperature heat pump		<input type="checkbox"/> Yes <input checked="" type="checkbox"/> No					
Integrated immersion heater for additional heat		<input checked="" type="checkbox"/> Yes <input type="checkbox"/> No					
Heat pump combination heater		<input checked="" type="checkbox"/> Yes <input type="checkbox"/> No					
Climate		<input checked="" type="checkbox"/> Average <input type="checkbox"/> Cold <input type="checkbox"/> Warm					
Temperature application		<input checked="" type="checkbox"/> Medium (55°C) <input type="checkbox"/> Low (35°C)					
Applied standards		EN 14825, EN 16147					
Rated heat output	Prated	4.0	kW	Seasonal space heating energy efficiency	η_s	129	%
Declared capacity for space heating at part load and at outdoor temperature T_j				Declared coefficient of performance for space heating at part load and at outdoor temperature T_j			
$T_j = -7\text{ °C}$	Pdh	3.6	kW	$T_j = -7\text{ °C}$	COPd	2.7	-
$T_j = +2\text{ °C}$	Pdh	3.3	kW	$T_j = +2\text{ °C}$	COPd	3.8	-
$T_j = +7\text{ °C}$	Pdh	3.0	kW	$T_j = +7\text{ °C}$	COPd	4.3	-
$T_j = +12\text{ °C}$	Pdh	2.6	kW	$T_j = +12\text{ °C}$	COPd	4.6	-
$T_j = \text{biv}$	Pdh	3.6	kW	$T_j = \text{biv}$	COPd	2.6	-
$T_j = \text{TOL}$	Pdh	3.6	kW	$T_j = \text{TOL}$	COPd	2.5	-
$T_j = -15\text{ °C}$ (if TOL < -20 °C)	Pdh		kW	$T_j = -15\text{ °C}$ (if TOL < -20 °C)	COPd		-
Bivalent temperature	T_{biv}	-8	°C	Min. outdoor air temperature	TOL	-10	°C
Cycling interval capacity	P_{cyc}		kW	Cycling interval efficiency	COP_{cyc}		-
Degradation coefficient	C_{dh}	0.97	-	Max supply temperature	WTOL	58	°C
Power consumption in modes other than active mode				Additional heat			
Off mode	P_{OFF}	0.01	kW	Rated heat output	P_{sup}	0.4	kW
Thermostat-off mode	P_{TO}	0.013	kW				
Standby mode	P_{SB}	0.013	kW	Type of energy input	Electric		
Crankcase heater mode	P_{CK}	0.02	kW				
Other items							
Capacity control	Variable		Rated air flow rate			230	m ³ /h
Sound power level	L_{WA}	42	dB				
Annual energy consumption	Q_{HE}	2505	kWh				
For heat pump combination heater							
Declared load profile for water heating	XL				Water heating energy efficiency	η_{wh}	124 %
Daily energy consumption	Q_{elec}	5.08	kWh	Daily fuel consumption	Q_{fuel}		kWh
Annual energy consumption	AEC	1116	kWh	Annual fuel consumption	AFC		GJ
Contact information	Quantum Energi AB - Ji-te gatan 7 - 265 38 Åstorp - Sweden						

QE-6

MODEL		QE-6					
Type of heat pump		<input type="checkbox"/> Air-water <input checked="" type="checkbox"/> Exhaust-water <input type="checkbox"/> Brine-water <input type="checkbox"/> Water-water					

MODEL		QE-6					
Low-temperature heat pump		<input type="checkbox"/> Yes <input checked="" type="checkbox"/> No					
Integrated immersion heater for additional heat		<input checked="" type="checkbox"/> Yes <input type="checkbox"/> No					
Heat pump combination heater		<input checked="" type="checkbox"/> Yes <input type="checkbox"/> No					
Climate		<input checked="" type="checkbox"/> Average <input type="checkbox"/> Cold <input type="checkbox"/> Warm					
Temperature application		<input checked="" type="checkbox"/> Medium (55°C) <input type="checkbox"/> Low (35°C)					
Applied standards		EN 14825, EN 16147					
Rated heat output	Prated	6.0	kW	Seasonal space heating energy efficiency	η_s	132	%
Declared capacity for space heating at part load and at outdoor temperature T_j				Declared coefficient of performance for space heating at part load and at outdoor temperature T_j			
$T_j = -7\text{ °C}$	Pdh	5.2	kW	$T_j = -7\text{ °C}$	COPd	2.7	-
$T_j = +2\text{ °C}$	Pdh	4.4	kW	$T_j = +2\text{ °C}$	COPd	3.7	-
$T_j = +7\text{ °C}$	Pdh	4.0	kW	$T_j = +7\text{ °C}$	COPd	4.3	-
$T_j = +12\text{ °C}$	Pdh	3.0	kW	$T_j = +12\text{ °C}$	COPd	4.6	-
$T_j = \text{biv}$	Pdh	5.2	kW	$T_j = \text{biv}$	COPd	2.7	-
$T_j = \text{TOL}$	Pdh	5.0	kW	$T_j = \text{TOL}$	COPd	2.6	-
$T_j = -15\text{ °C}$ (if TOL < -20 °C)	Pdh		kW	$T_j = -15\text{ °C}$ (if TOL < -20 °C)	COPd		-
Bivalent temperature	T_{biv}	-7	°C	Min. outdoor air temperature	TOL	-10	°C
Cycling interval capacity	P_{cyc}		kW	Cycling interval efficiency	COP_{cyc}		-
Degradation coefficient	C_{dh}	0.97	-	Max supply temperature	WTOL	58	°C
Power consumption in modes other than active mode				Additional heat			
Off mode	P_{OFF}	0.01	kW	Rated heat output	P_{sup}	1.0	kW
Thermostat-off mode	P_{TO}	0.013	kW				
Standby mode	P_{SB}	0.013	kW	Type of energy input	Electric		
Crankcase heater mode	P_{CK}	0.02	kW				
Other items							
Capacity control	Variable			Rated air flow rate		230	m ³ /h
Sound power level	L_{WA}	42	dB				
Annual energy consumption	Q_{HE}	3671	kWh				
For heat pump combination heater							
Declared load profile for water heating	XL			Water heating energy efficiency	η_{wh}	124	%
Daily energy consumption	Q_{elec}	5.08	kWh	Daily fuel consumption	Q_{fuel}		kWh
Annual energy consumption	AEC	1116	kWh	Annual fuel consumption	AFC		Gj
Contact information	Quantum Energi AB - Ji-te gatan 7 - 265 38 Åstorp - Sweden						

Index

B

Before installing
Transport [5](#)

C

Comfort disturbance [26](#)
Troubleshooting [26](#)
Components
Electrical box [9](#)
Fuses [15](#)
Hydronic unit connections [8](#)
Overview [8](#)
Ventilation unit [8](#)

E

Electrical connections [16](#)
1x230V [16](#)
3x400V [17](#)
Power connection [16](#)
Sensors [17](#)
Indoor temperature sensor [18](#)
Outdoor temperature sensor [18](#)
Electrical installation [15](#)
Access
Electrical box [15](#)
Safety temperature limiter [18](#)
Environmental information [3](#)

F

Front cover removal [6](#)
Disconnecting the display unit [7](#)

I

Important information
Environmental information [3](#)
Product labels [3](#)
Safety [3](#)
Serial number [3](#)
Installation area [5](#)
Setup dimensions [5](#)

O

Operating principle [10](#)

P

Pipe connections [11](#)
Measurements and dimensions [11](#)
Pipe installation [10](#)
Cold and domestic hot water [12](#)
Distribution system [11](#)

S

Safety temperature limiter [18](#)
Setup dimensions [5](#)
Supplied components [5](#)
System volume [10](#)

T

Technical specifications [28](#)
Dimensions and installation coordinates [28](#)
Energy labelling [29](#)
Technical data [28](#)
Transport [5](#)

V

Ventilation installation [12](#)
Measurements and dimensions [13](#)
Ventilation flow and adjustments [14](#)

QCH EN 2410-2



TD3

This publication presents information that was valid at the time of publishing.
Quantum reserves the right to make changes without prior notification.
Subject to possible printing errors.
©2024 Quantum Energi AB

HEAT PUMPS FOR SUSTAINABLE CITIES

WE CHANGE THE WAY THE CITIES OF EUROPE ARE HEATED

Quantum, founded in Sweden in 1993, develops high-quality heat pumps for individual buildings and innovative heat pump-based solutions for densely populated areas to enable everybody to benefit from emission free heating and cooling. The company has deep knowledge in both heat pump technology and energy systems engineering and works in close collaboration with engineering consultants, installers, project developers and utilities.

Quantum Energi AB

Ji-te gatan 7, 265 38 Åstorp – Sweden | quantum.com



Q V A N T U M