

Quantum QH

Hydronic unit



Installation and user handbook

QCH EN 2423-1
2345

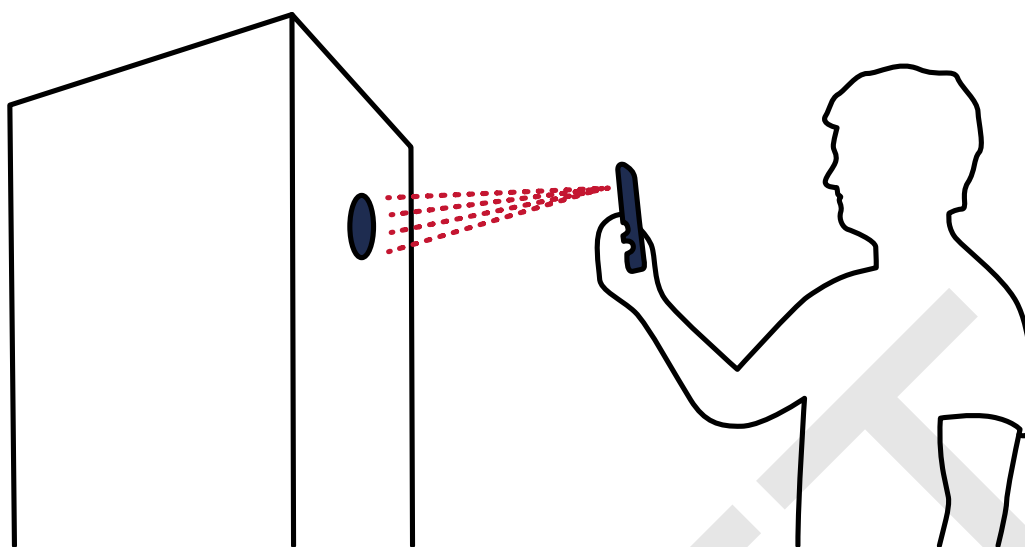

QVANTUM APP

Have all the controls for your heat pump, in the palm of your hand.

The Qvantum app is a necessary companion for installing and setting up your Q unit. The app is available on both App Store and Google Play.

By scanning the QR code on your Q unit, you can connect to the unit through Wi-Fi or Bluetooth. During commissioning, you will be guided through the entire installation process.

Once the connection is established, you can use the app to access all relevant information and settings for your product.

CONTENTS

1 Important information.....	4	10 Technical specifications.....	25
General.....	4	Dimensions.....	25
Safety.....	4	Technical data.....	26
Symbols.....	4		
Product labels.....	4		
Serial number and QR code.....	4		
Product registration.....	4		
Environmental information.....	4		
Glossary.....	5		
2 Before installing.....	6		
Transport.....	6		
Installation area.....	6		
Additional components.....	6		
Front cover removal.....	7		
3 Components.....	8		
Overview.....	8		
Plumbing connections.....	8		
Electrical box.....	8		
4 Pipe installation.....	9		
Pipe installation, general.....	9		
Pipe connections.....	10		
Installation.....	10		
5 Electrical installation.....	12		
Electrical installation, general.....	12		
Electrical connections.....	13		
Safety temperature limiter.....	15		
6 Commissioning.....	16		
Quantum app.....	16		
Preparations.....	16		
Filling.....	16		
Venting.....	16		
First start-up.....	17		
7 User interface.....	18		
Introduction.....	18		
Using the display unit.....	18		
Display pages.....	18		
8 Service.....	20		
General.....	20		
Maintenance.....	20		
Service actions.....	20		
9 Troubleshooting.....	23		
Before troubleshooting.....	23		
Low room temperature during heating.....	23		
High room temperature during heating.....	23		
Insufficient hot water production.....	23		
Low system pressure.....	24		

1 IMPORTANT INFORMATION

General

WARNING

Read this manual before starting the unit for the first time.

It is the owner of the product that is responsible for the system. If you suspect that the product is defective, contact your dealer.

Safety

Companies and service technicians who install or perform maintenance work on the product must be authorized and have the necessary certificates and licenses.

The work must follow applicable rules and regulations. Ensure that the work is carried out in a professional manner.

The manual must be available for people who install, support or use the heat pump.

CAUTION

This appliance can be used by children from 8 years and above and people with reduced physical, sensory or mental capabilities or lack of experience and knowledge if they have been given supervision or instruction concerning the use of the appliance in a safe way and understand the hazards involved. Children must not play with the appliance. Cleaning and maintenance must not be performed by children unless they are older than 8 and supervised.

Symbols

The manual contains the following symbols

WARNING

This symbol describes information that is of great danger to people or equipment.

CAUTION

This symbol describes information that could cause danger to people or equipment.

NOTE

This symbol describes information that is crucial when installing or servicing the heat pump.

TIP

This symbol describes information that can be helpful when installing or servicing the heat pump.

Product labels

These labels are found on the product.

 CE marking indicates that a product has been assessed by the manufacturer and deemed to meet EU safety, health and environmental protection requirements.

IP21 Protection classification against water and dust in the electrical enclosure.

Serial number and QR code

The serial number and QR code of the QH are visible at the following locations.

- Electrical box cover
- Packaging
- Display unit.

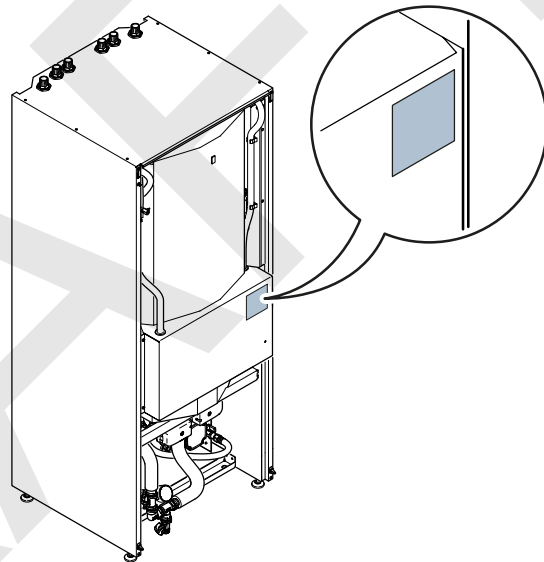

Product registration

The product must be registered for the warranty to take effect.

The product can be registered no more than 12 months after the delivery date from the factory and no more than one month after the installation. If the product is registered at a later stage, the warranty and insurance period is counted down.

The product registration is done as part of the start-up guide in the Quantum app.

Environmental information

Recycling

 At the end of the electrical products useful life, it must not be disposed of with household waste.

Recycle at waste facility. Check with your local authority or retailer for local recycling regulations.

Packaging content

The product packaging contains the following materials.

MATERIAL	WEIGHT
Paper	3700 g
Plastic	470 g
Wood (pallet)	6 kg
Steel (reinforcement on pallet)	0.5 kg

Glossary

The following terms are used throughout the manual to describe various functions of the product.

Distribution system

The distribution system is the system that is used to provide the house with heating through radiators, floor heating and/or fan convectors.

Hydronic unit

The hydronic unit consists of an accumulator tank, pipe connections, electrical connections and the graphical user interface. It provides the house with domestic hot water as well as heating through the distribution system.

Heat pump unit

The Quantum QH is installed together with a heat pump unit that is placed outside of the facility. The outdoor heat pump unit draws heat from the outdoor air and transfers it to the hydronic unit .

2 BEFORE INSTALLING

Transport

Transport the unit in an upright position. Ensure that the unit is adequately secured so it does not fall down during transit.

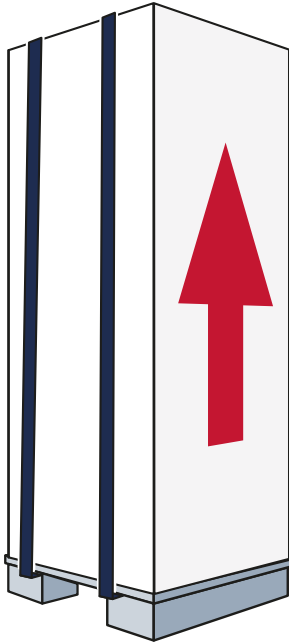

At arrival, ensure that the product was not damaged during transport.

If the unit must be tilted after arrival, always tilt it backwards.

If using a trolley or hand truck when moving the unit, always have the unit standing on the pallet.

Installation area

Ensure that the following installation area requirements are fulfilled.

- The foundation withstands the weight of the unit when it is filled.
- The foundation is waterproof and equipped with a floor drain.
- The area is frost-free.

i TIP

The feet under the unit must be adjusted to ensure that the product is stable and positioned in level. Use a wrench or an open end spanner (size 17) to adjust the feet.

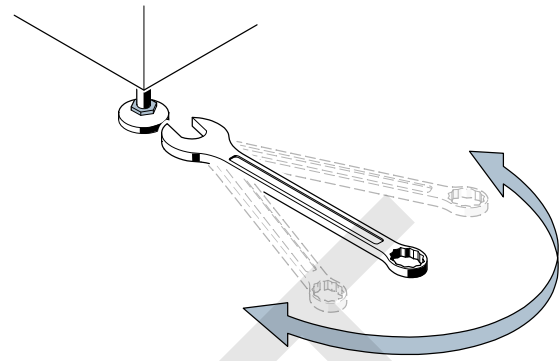

Setup dimensions

! CAUTION

A minimum of 800 mm free space must be available in front of the product.

The unit must not be placed in direct connection to the background wall or in connection to adjacent interior details as it can create unwanted noise. A minimum of 10 mm of clear space should be left behind and next to the unit.

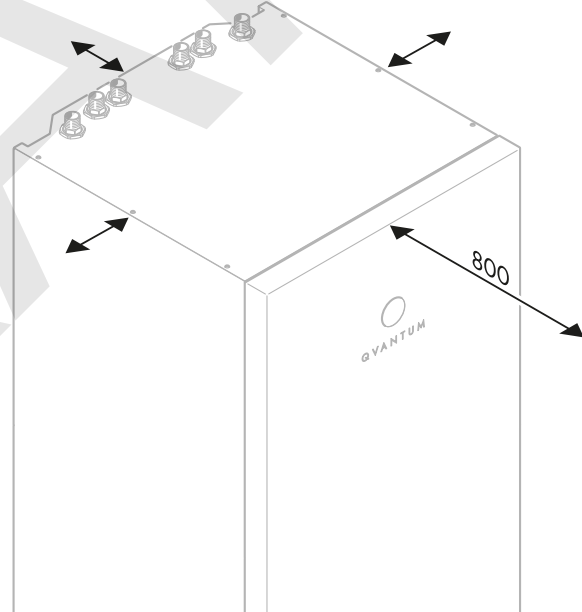

Additional components

Supplied components

The supplied components package contains the following items:

- Two filterball valves
- Outdoor sensor
- Indoor sensor
- 3-pin busbar
- Snap-on ferrite core

Accessories

The product can be complemented with the following accessories.

ACCESSORY	PART NUMBER
Extension base	9330549

Front cover removal

The front cover of the unit is mounted with clips that are on the frame of the product. The cover rests on brackets that are on the top of the frame.



NOTE

Be careful when removing the hydronic unit cover to avoid causing damage to the ethernet cable and display unit.

1. Carefully pull the bottom of the cover from the hydronic unit.
2. Lift the cover upwards.
3. Remove the cover from the unit.

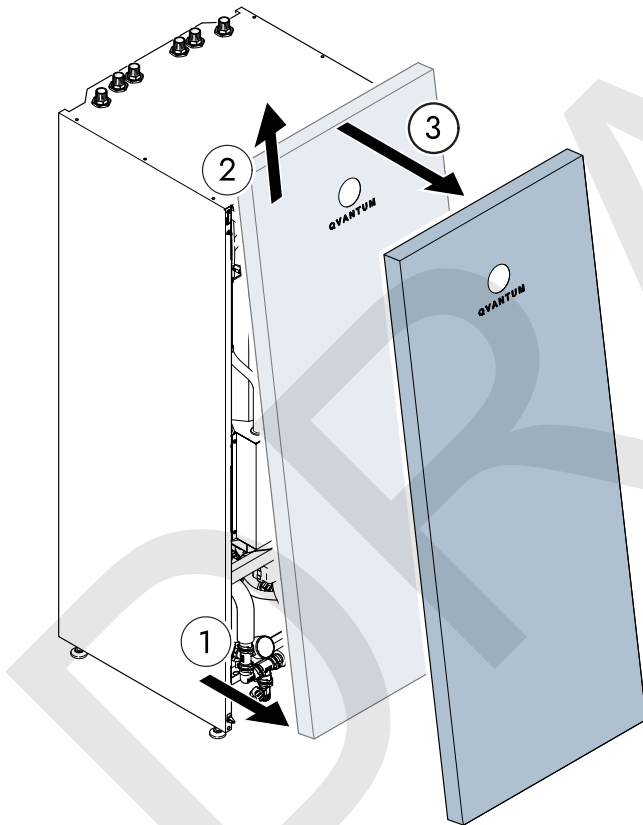

Disconnecting the display unit

The display unit is connected with an ethernet cable on the front cover. Remove the ethernet cable before moving the front cover too far away from the hydronic unit.

For most installation and servicing tasks, disconnecting the display unit is not necessary. The display cable is long enough for placing the front cover in close proximity to the unit.

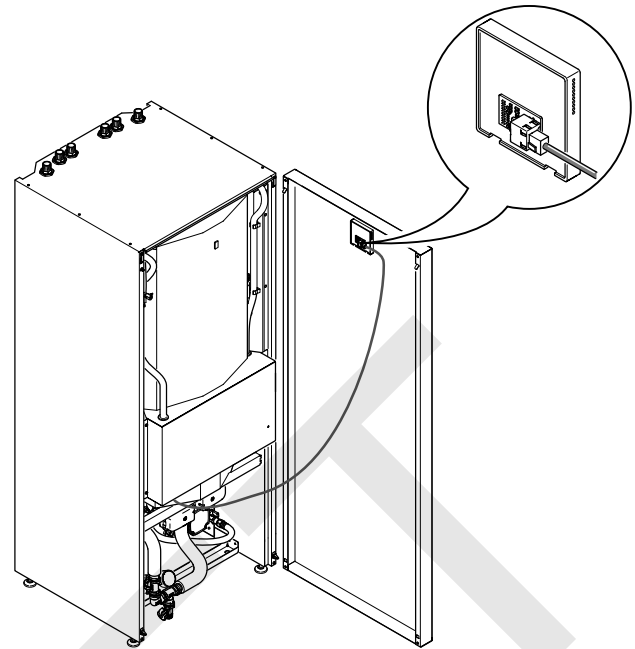

1. Press the tab on the ethernet plug.
2. Disconnect or connect the ethernet plug.

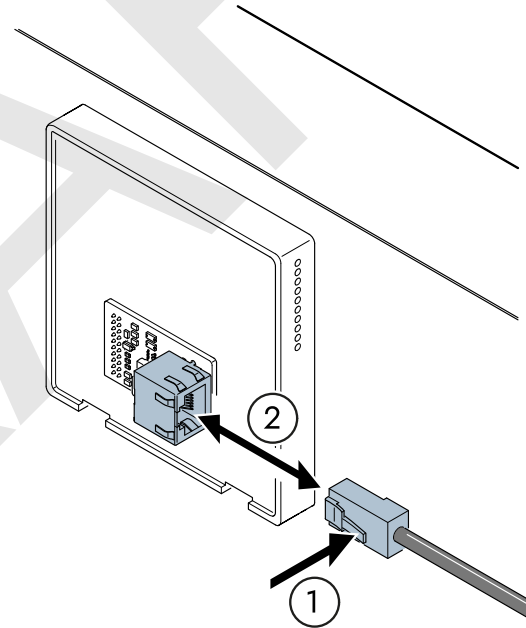

3 COMPONENTS

Overview

The Quantum QH is a hydronic unit that is installed with a heat pump unit.

The hydronic unit is connected to the facility's piping system through connections that are on the top of the unit.

Plumbing connections

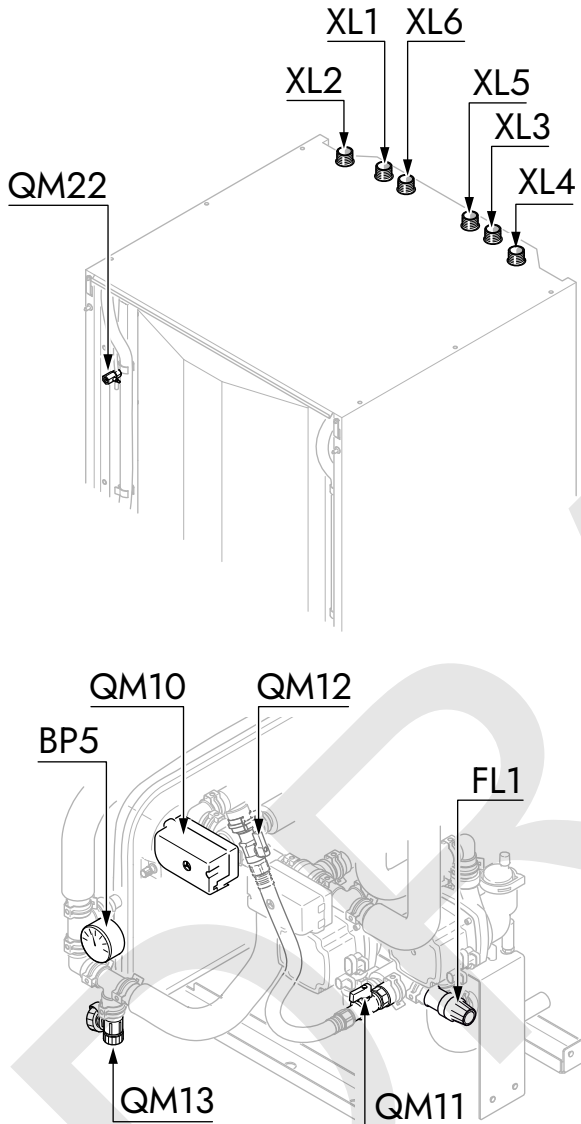

ID ¹	COMPONENT
XL1	Connection distribution system, supply line
XL2	Connection distribution system, return line
XL3	Connection, cold water
XL4	Connection, hot water
XL5	Connection heating medium, supply from heat pump
XL6	Connection heating medium, return to heat pump
QM10	Diverting valve
QM11	Primary refill valve, distribution system
QM12	Secondary refill valve, distribution system
QM13	Drain valve, accumulator tank

ID ¹	COMPONENT
QM22	Bleed valve, accumulator tank
FL1	Safety valve, hot water tank
BP5	Pressure gauge

¹ Component designations in accordance with IEC 81346.

Electrical box

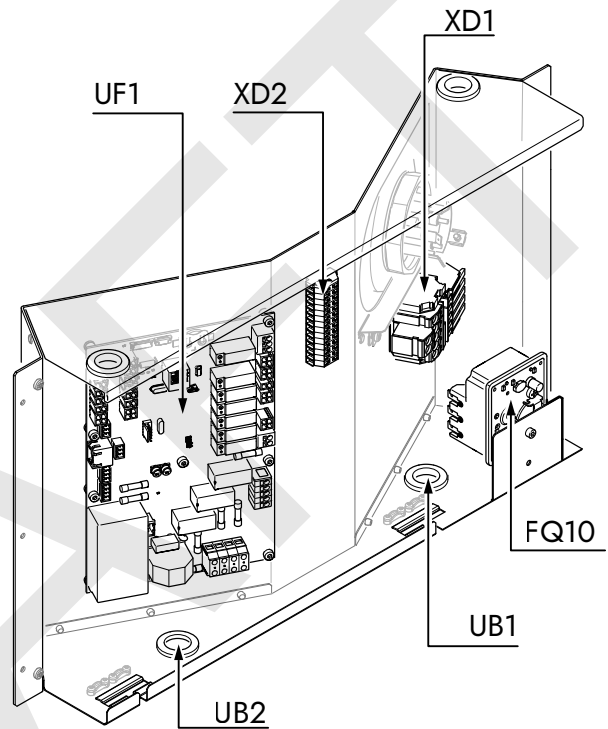

ID ¹	COMPONENT
FQ10	Safety temperature limiter (STL)
UB1	Cable entry, power supply
UB2	Cable entry, communication and sensors
UF1	Main board
XD1	Terminal block, power supply
XD2	Terminal block, communication and sensors

¹ Component designations in accordance with IEC 81346.

4 PIPE INSTALLATION

Pipe installation, general

NOTE

The pipe installations must be performed in accordance with applicable regulations.

All pipe connections face the top of the unit. The radiator system must be correctly adjusted so that the house has a balanced heat transfer.

CAUTION

The unit is not equipped with a safety valve for the distribution system. Ensure that an external safety valve for the distribution system is installed.

For best performance and operational reliability, the maximum allowed supply line temperature should not exceed 55 °C.

CAUTION

The temperature settings must be adjusted to accommodate the highest allowed supply line temperature of the distribution system. Not setting the correct temperatures can cause serious structural damage.

CAUTION

To avoid damage to components, ensure that the piping system is flushed out before connecting the heat pump.

CAUTION

The quality of incoming water must fulfill the requirements declared in EU directive 2020/2184.
If the unit is installed where a private well is used it may be necessary to add an extra water filter

Operating principle

The hydronic unit gets the charge flow from the heat pump unit (1) via XL5 (2). Depending on the demand, the heat is then distributed to heating or domestic hot water via a diverting valve (3). It will then be returned to the heat pump unit via XL6 (4) for collection of new energy.

If the compressor can not cover the demand in cold weather conditions, the mixing valve (5) starts to open, allowing additional heat stored in the accumulator tank to be distributed.

At this stage, the temperature in the tank will be maintained by the built-in immersion heater (6) which is switched on in stages as needed

Hot water circulation (7) is installed outside of the unit.

NOTE

The following image is a principle picture. The locations of components do not correspond with the actual product.

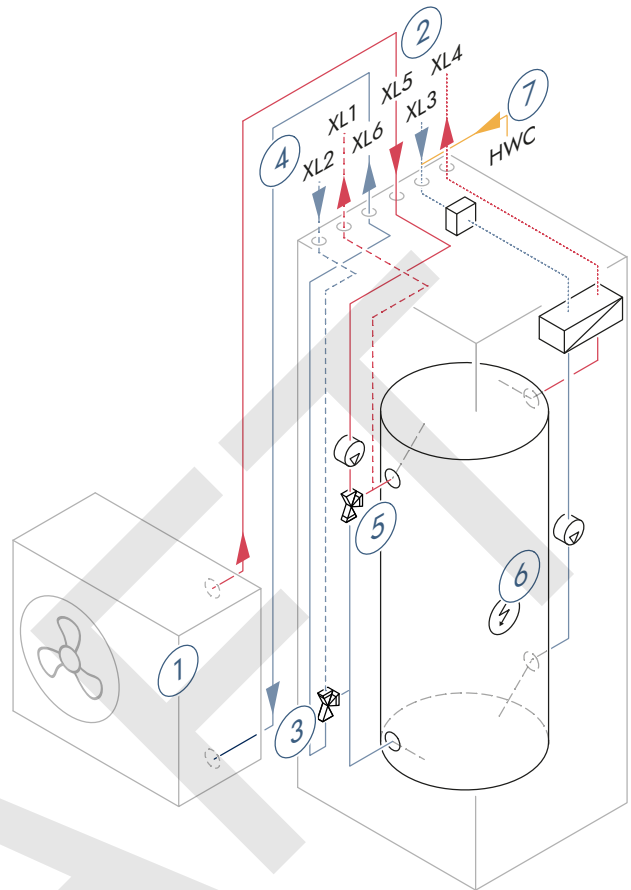

System volume

The expansion vessel in the unit has a volume of 12 litres. The vessel has a pre-pressure of 0.5 bar. It is recommended that the height difference between the expansion vessel and the highest installed radiator does not exceed five meters ("Max" in the following image).

The height difference is measured between the center of the expansion vessel and the top-level radiator.

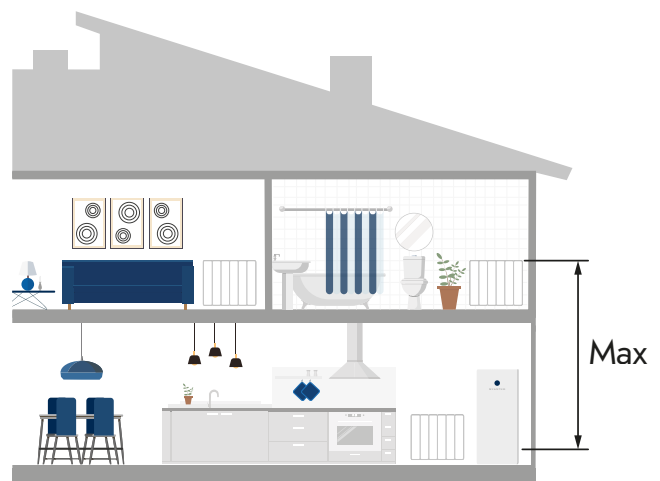

NOTE

If the pre-pressure is too low, the valve on the expansion vessel can be used for refilling of nitrogen. Changing the pre-pressure can affect the expansion vessel's capacity for accommodating the expansion of the water.

At the default pre-pressure of 0.5 bar, the maximum system volume is 200 litres.

Pipe connections

Measurements and dimensions

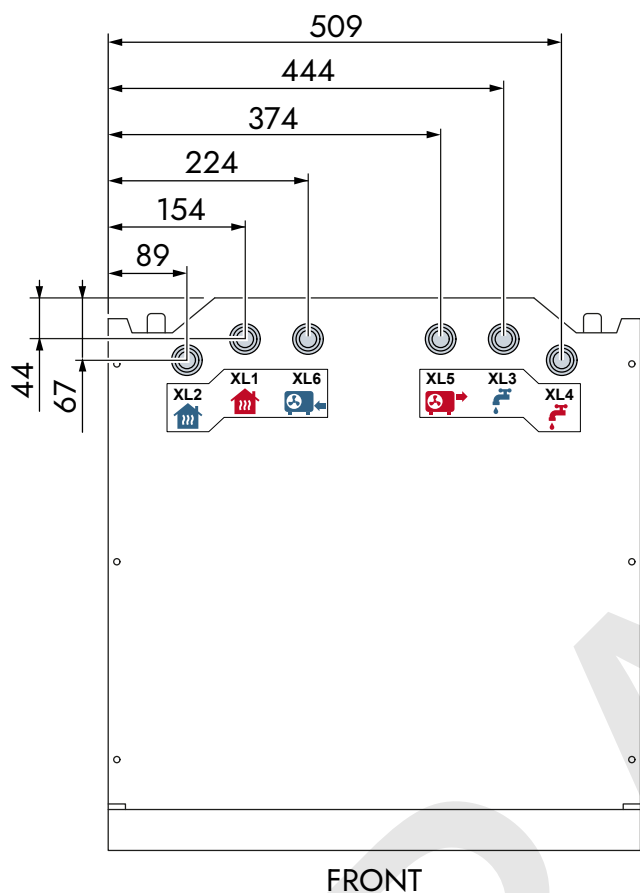

CONNECTION	DIMENSION
XL1, distribution system supply	DN20, external thread
XL2, distribution system return	DN20, external thread
XL3, cold water	DN20, external thread
XL4, hot water	DN20, external thread
XL5, outdoor unit supply	DN20, external thread
XL6, outdoor unit return	DN20, external thread

Installation

Standalone installation

This section applies to applications where the hydronic unit is installed without an external heat pump unit, making the hydronic unit work as a standalone electric heating boiler.

The unit is not equipped with a safety valve for the distribution system. If installed as a standalone electric heating boiler, a safety valve with an opening pressure of 3 bar must be installed.

1. Mount a safety valve with an opening pressure of 3 bar on docking pipe connection XL5.

2. Bridge the docking pipe connections (XL5 and XL6).

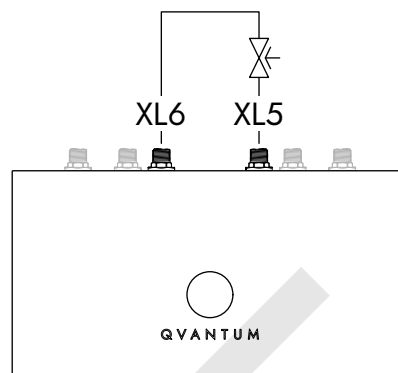

Distribution system

! CAUTION

If the water in the distribution system is aggressive or lime-rich, use a water treatment additive to avoid damages to components.

NOTE

Ensure that sufficient system flow passes through the product. Fully opened thermostats helps maintain sufficient system flow and reduce the risk of operational disturbances.

The distribution system is used to accommodate the indoor comfort demands of the property. The control system adjusts to the comfort demands through heating suppliers, like for example radiators or floor heating.

- Connect the return line from the distribution system to the return connection (XL2).
- Connect the supply line to the distribution system to the supply connection (XL1).

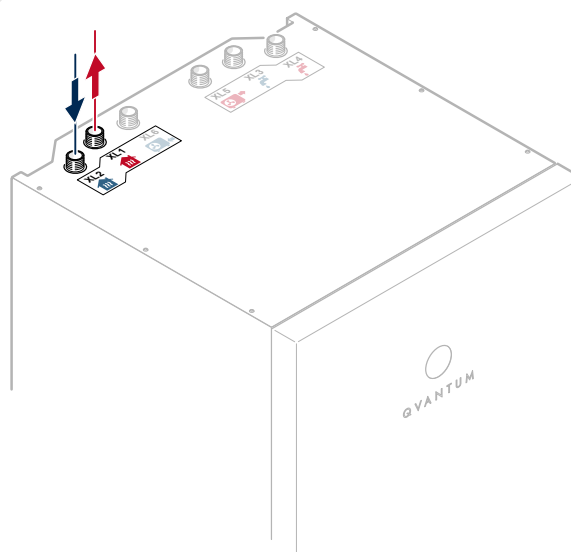

Cold and domestic hot water

- Attach the supplied filterball valve between the cold water main and the cold water connection (XL3).
- Connect the cold water supply to the cold water connection (XL3).

- Connect the domestic hot water system to the hot water connection (XL4).

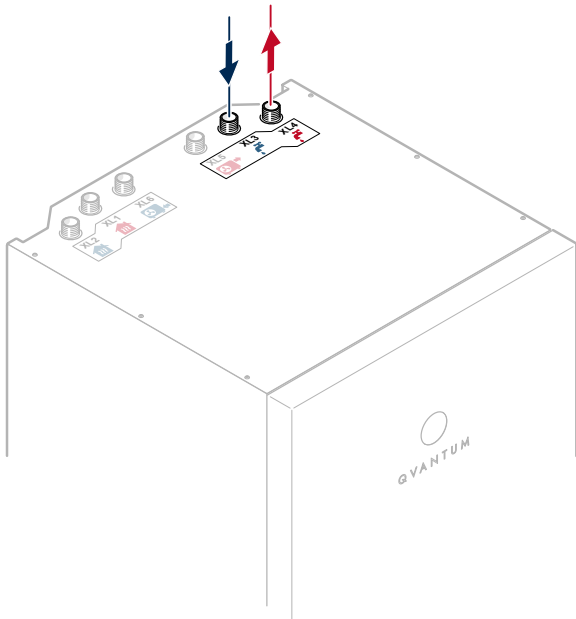

Heat pump unit

- Connect the heat pump unit supply line to the heating medium supply connection (XL5).
- Attach the supplied filterball valve between the heat pump unit and the heating medium connection (XL6).
- Connect the heat pump unit return line to the heating medium return connection (XL6).

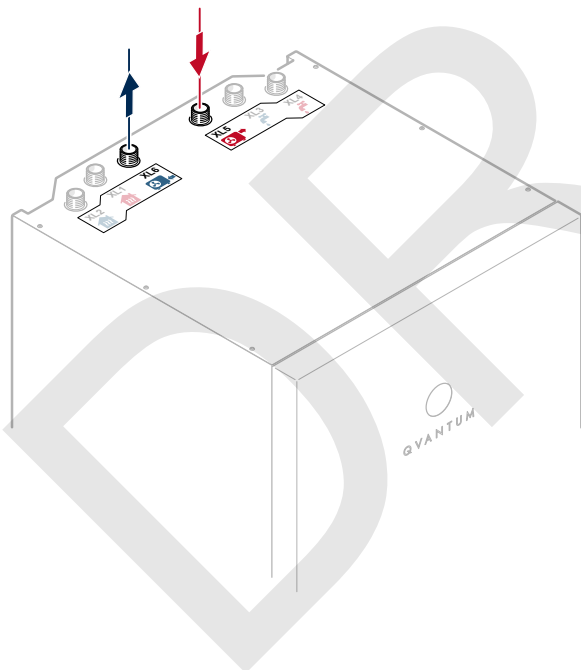

5 ELECTRICAL INSTALLATION

Electrical installation, general

WARNING

All electrical connections must be performed by a qualified electrician and in accordance with applicable regulations.

CAUTION

Do not start the unit until it has been filled with water and all electrical connections have been checked. Premature start-up can cause damage to internal components.

- The unit must be disconnected before the house wiring is insulation tested.
- Power cables should be placed at least 200 mm from communication and sensor cables.
- It is recommended that the heat pump is installed with a separate residual current device (RCD, type B) with a tripping current of 30 mA.

Cable channels

The unit has cable channels on the back of the unit. The channels are made of flexible hoses and are used to reach internal electrical connections.

ID	CONNECTION TYPE
UB1	Power supply
UB2	Communication and external connections

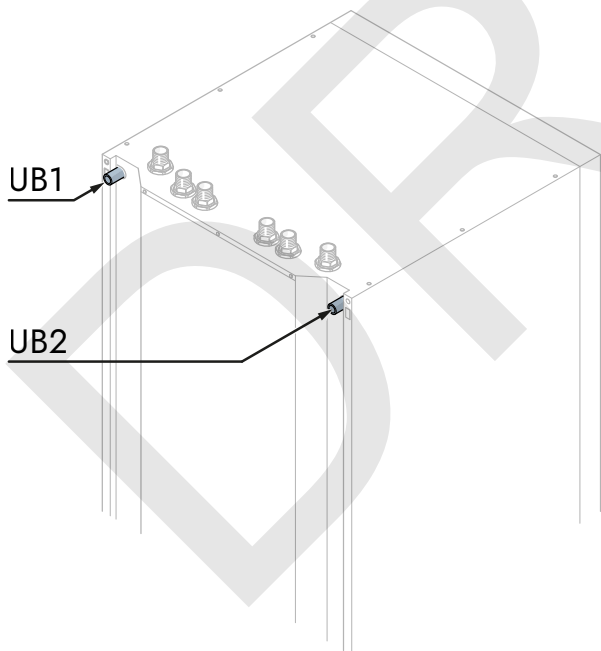

Access

Electrical box

The electrical box is located behind the front cover of the hydronic unit.

Remove the screws of the electrical box cover.

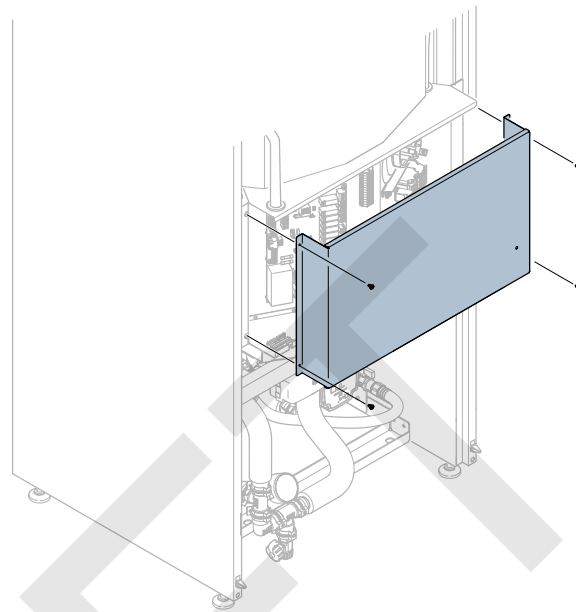

Fuses

The fuses are located on the circuit board (UF1) in the electrical box.

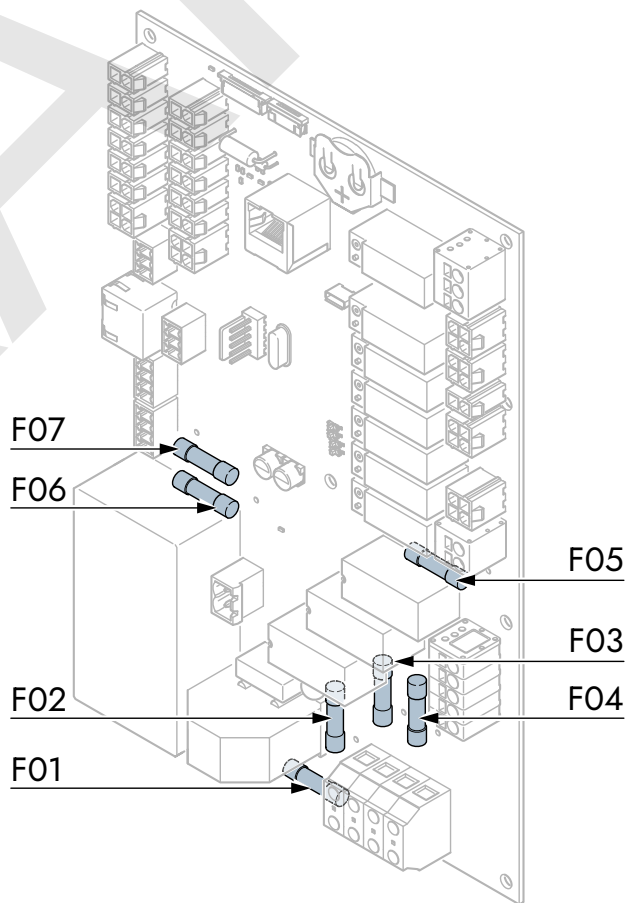

ID ¹	DESTINATION	FUSE SIZE
UF1:F01	Internal 230 V	4 A
UF1:F02	Heat element (L1)	10 A
UF1:F03	Heat element (L2)	10 A
UF1:F04	Heat element (L3)	10 A

ID ¹	DESTINATION	FUSE SIZE
UF1:F05	External 230 V	2 A
UF1:F06	Internal 24 V	630 mA
UF1:F07	External 24 V	500 mA

¹ Component designations in accordance with IEC 81346.

Electrical connections

Power connection

The QH can be installed in single or three phase applications.

An isolator switch with a 3mm minimum breaking distance must be used to install the unit. Size the minimum cable area in accordance with the fuse rating that is being used. Dimension the fuse size according to the following table.

1X230V	3X400V
35 A (class C)	16 A (class C)

To connect the power supply, open the terminal block lever (1), insert the cable (2) and close the lever (3).



NOTE

The cable strip length should be 13–15mm.

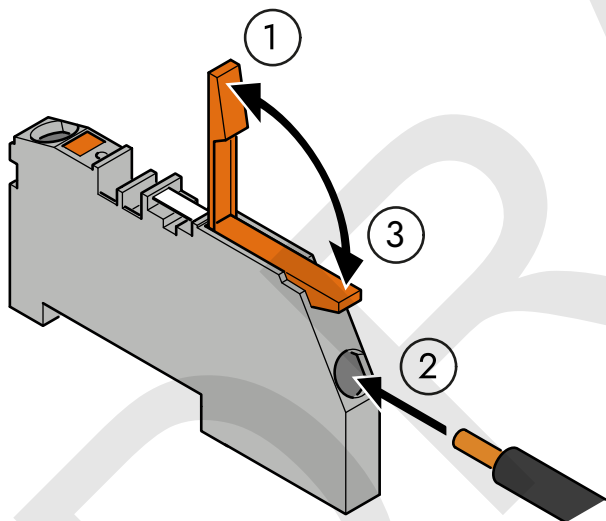

1x230V

For single-phase installations, the supplied 3-pin busbar must be used to bridge the phases on terminal block XD1.

1. Attach the supplied 3-pin busbar so it bridges connections XD1:L1, L2 and L3.

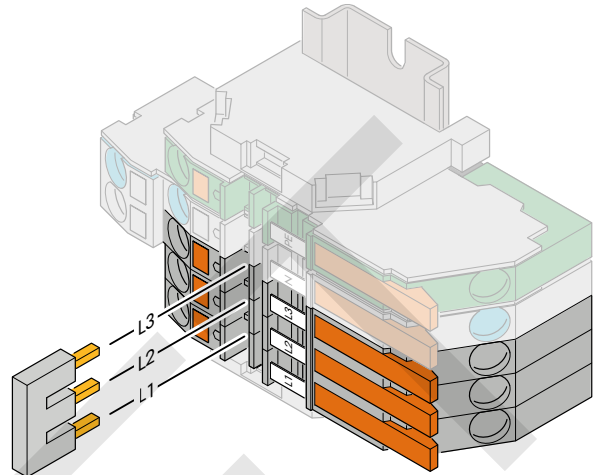

2. Connect the power supply to terminal block XD1.

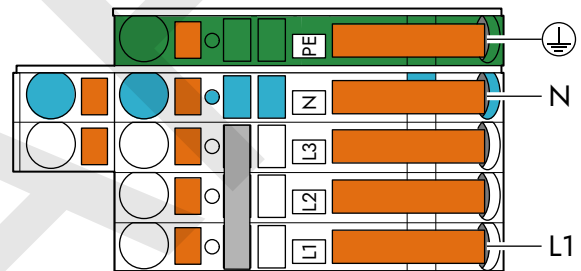

3x400V

1. Dispose of the supplied 3-pin busbar.

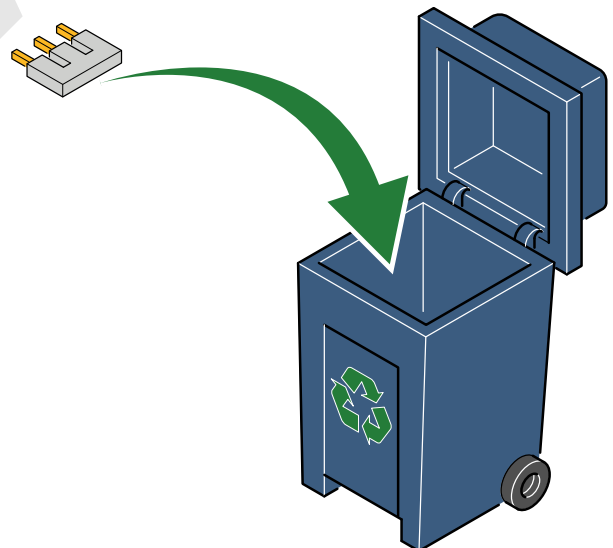

2. Connect the power supply to terminal block XD1.

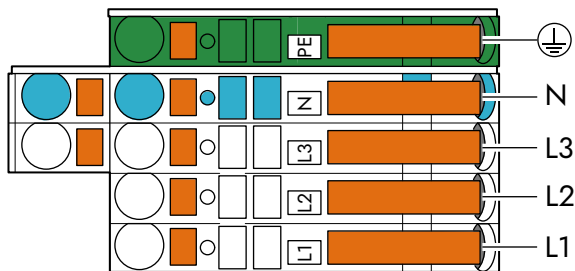

Heat pump unit

Connect the communication from the outdoor unit to the MODBUS 3 socket on the main board (UF1).

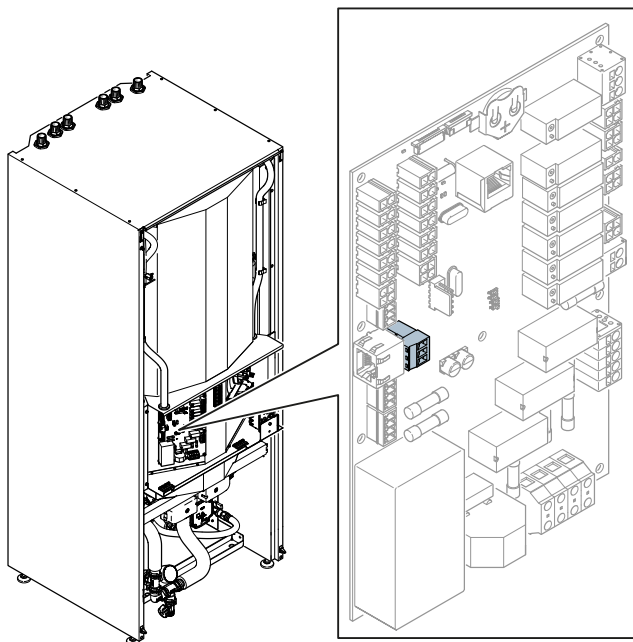

1. Remove the connector from the MODBUS 3 socket on the main board (UF1).
2. Attach the wires to the connector.
 - a) Connect the communication wiring from the outdoor unit to UF1:MODBUS 3.

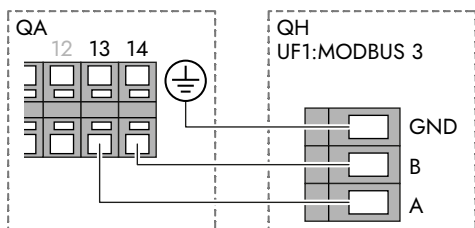

3. Reattach the modbus connector to the MODBUS 3 socket.

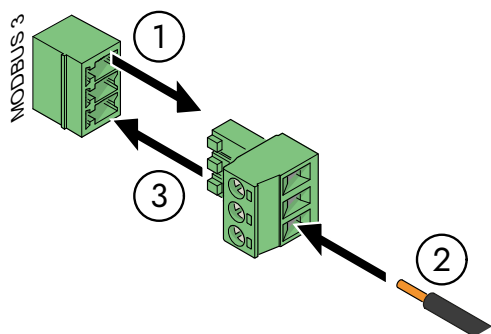

Sensors

The cables are connected to spring loaded terminal blocks on XD2.

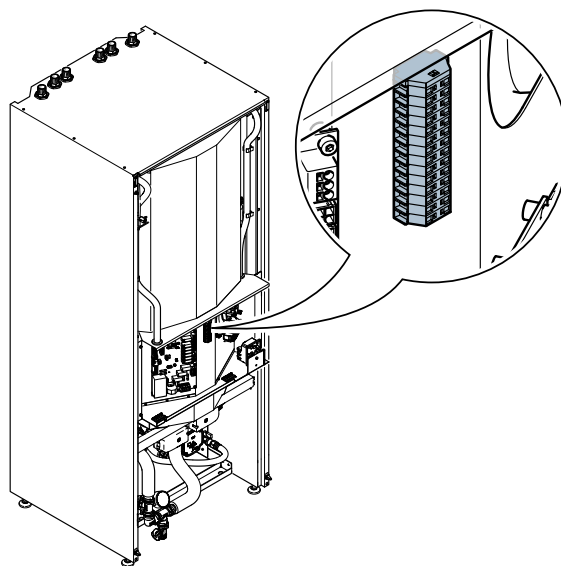

The cables should have an area of 0.5mm² with a cable length up to 50 m.

Connect the cables by inserting a screwdriver or similar at the top of the terminal block (1). When the spring in the terminal block is open, insert the cable (2).

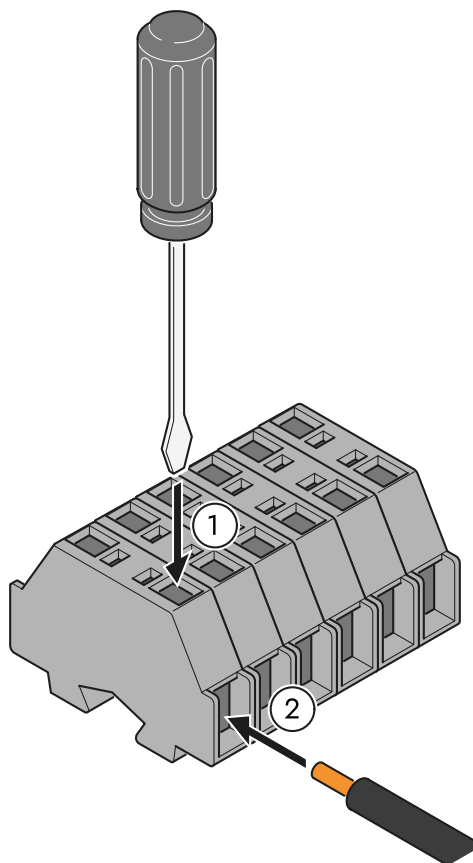

Ferrite core

For electrical shielding purposes, all sensor cables should be routed through the supplied ferrite core (FE1).

The supplied ferrite core (FE1) must be placed outside of the QH. It is recommended that the ferrite core is mounted at the outlet of the cable channel for external connections (UB2).

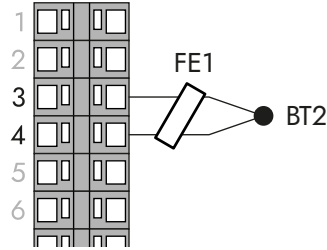
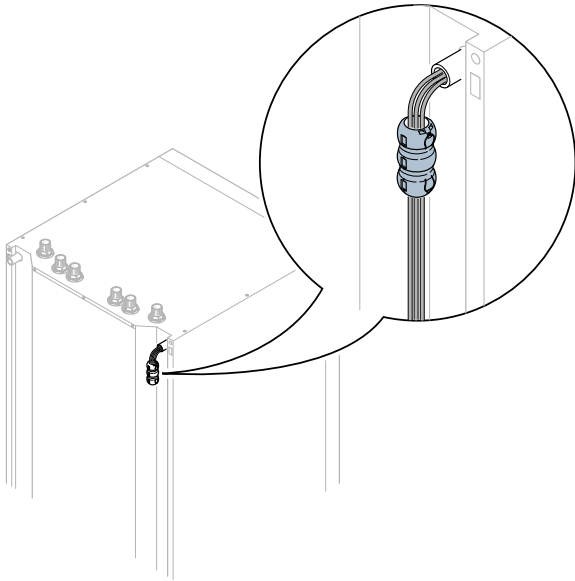

Safety temperature limiter

The unit is equipped with a safety temperature limiter that is behind the cover of the electrical box. If the temperature reaches 95 °C, the safety temperature limiter will stop the power to the immersion heater.

! CAUTION

Verify that the safety temperature limiter has not been triggered prior to installation.

A manual reset is required if the safety temperature limiter has been triggered. By pushing the button that can be accessed through a hole in the electrical box cover, the limiter is reset.

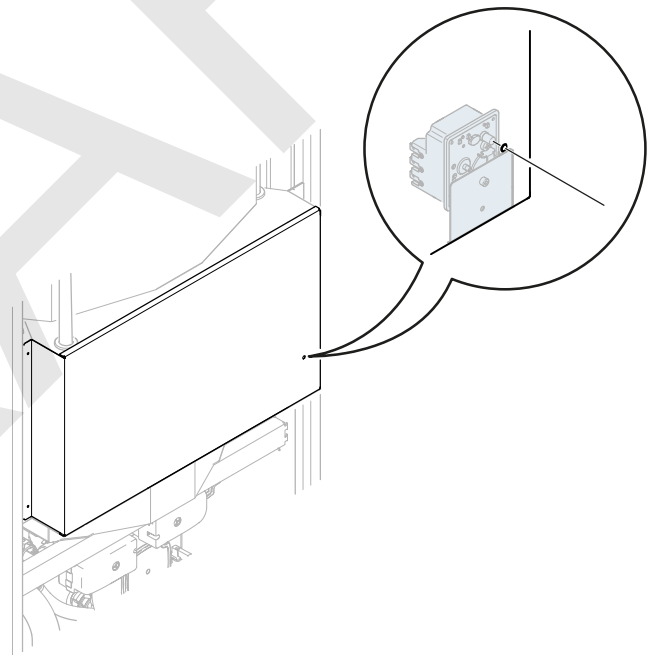

Outdoor temperature sensor

The outdoor temperature sensor (BT1) must be positioned so that it can give an accurate temperature reading. The sensor location should be protected from sun exposure and is preferably installed in a shaded area to the north or northwest.

To prevent condensation in the sensor chamber, seal the tube the cable is running through.

Route the cable through the supplied ferrite core (FE1).

Connect the outdoor temperature sensor (BT1) to terminal blocks XD2:1-2.

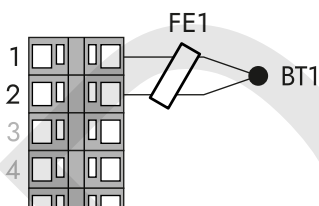

Indoor temperature sensor

The indoor temperature sensor (BT2) enables monitoring and control of the indoor temperature. Installing the indoor sensor is not mandatory, but necessary for reading the indoor temperature.

The sensor should be positioned so that it can give an accurate temperature reading, about 1.5 meters above the floor. Avoid placing it near heaters, radiators, windows, front doors, or anything else comparable. It must not be covered, exposed to air currents, or exposed to heat sources.

Route the cable through the supplied ferrite core (FE1).

Connect the indoor temperature sensor (BT2) to terminal blocks XD2:3-4.

6 COMMISSIONING

Quantum app

To properly set up the unit, install the Quantum app and follow the in-app instructions.

The app contains an installation checklist that helps you control all parts of the installation before starting the heat pump for the first time.

At first start-up of the unit, the app helps you set up the machine.

Preparations

1. Ensure that the unit is turned off.
2. Ensure that the filling valves (QM11, QM12) are entirely closed.



NOTE

The filling valves must be closed during normal operation.

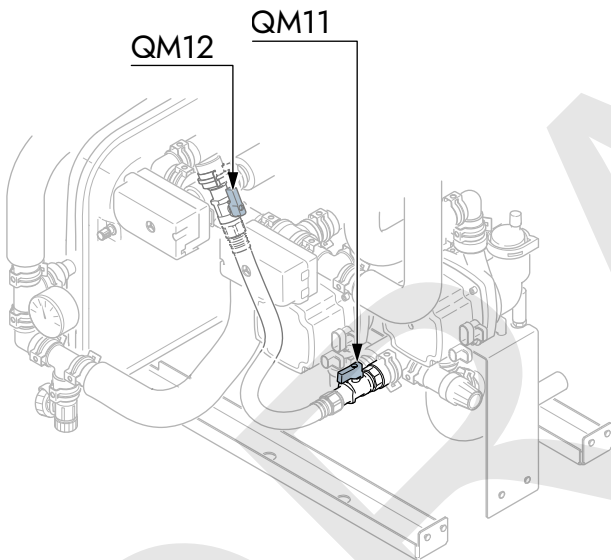

Filling

Water heater

1. Ensure that the filter ball valve that is connected to the cold water connection (XL3) is open.
2. Open one of the facility's hot water taps.
3. Open the facility's main cold water valve.

When no more air comes from the hot water tap, close the tap.

Distribution system

Attach a hose to the bleed valve before opening it.

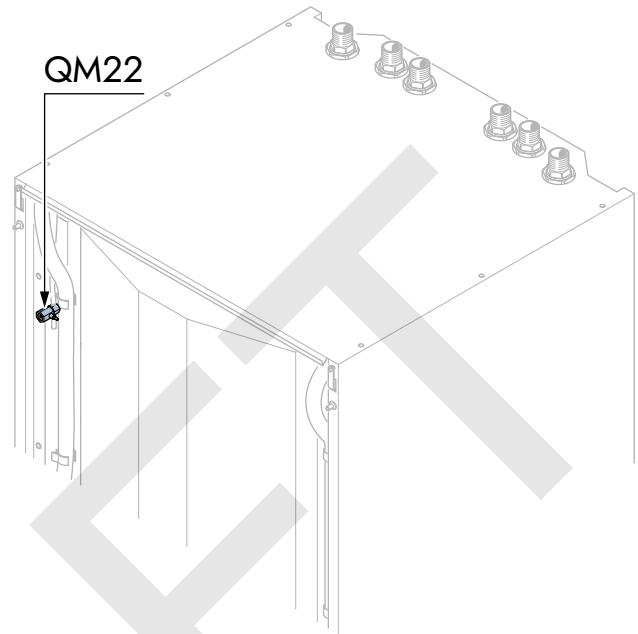

1. Open the bleed valve for the accumulator tank (QM22).
2. Ensure that the hose between the filling valves is securely attached.
3. Open the filling valves (QM11 and QM12)
The distribution system and accumulator tank will be filled with water.
4. Wait until air stops coming from the bleed valve (QM22) and close it.
5. Close the filling valves.
6. Reduce the distribution system pressure to approximately 1 - 1.5 bar.
 - a) Reduce the distribution system pressure by opening the bleed valves or the safety valve.
7. Start up the heat pump unit.
8. Start up the hydronic unit.
 - a) Allow the hydronic unit to run for one heating cycle and one hot water cycle.
9. Ensure that the hydronic unit provides room heating and hot water.
10. Open the bleed valve.
11. Wait for the bleed valve to be completely purged.
12. Close the bleed valve.

Venting

Distribution system

1. Turn off the unit and wait for at least 30 seconds.
2. Turn off the power supply to the unit.
3. Purge the unit by opening the bleed valve (QM22).
4. Refill and purge the distribution system until all air is removed and adequate system pressure is reached.

First start-up

! CAUTION

Before the first start-up, ensure that there is no frozen water in the system.

NOTE

Before the first start-up, ensure that there is water in the distribution system.

1. Turn on the system.
2. Set up the system by following the steps shown in the display unit.

To adjust the settings after the first start-up, use the display unit or the Quantum app. The most common settings are available in both the display unit and the app. To access more advanced settings, the app must be used.

If the property is cool at commissioning, the internal additional heating might be activated to help the compressor satisfy the heating demand.

Pump speed

The speed of the heating medium pump is adjusted through the Quantum app.

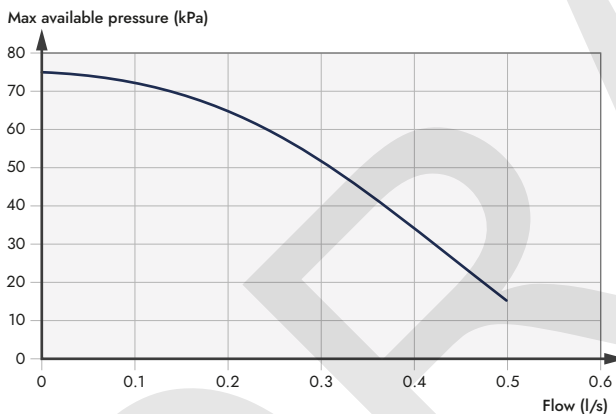

7 USER INTERFACE

Introduction

The Quantum QH is equipped with a user friendly touchscreen display. Through the display, the most necessary settings can be accessed and adjusted.

More settings are available through the Quantum app.

Using the display unit

Use the arrow buttons (1) on the sides of the interface to access the different pages in the display unit.

For display pages with settings, use the slider (2) at the bottom of the display to adjust the settings. The default value for the setting is shown with a black line within the slider (3).

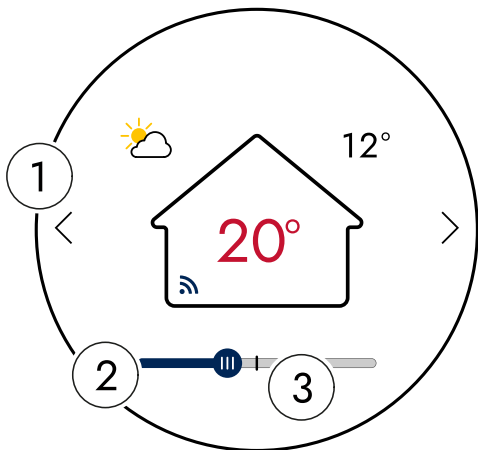

Swipe upwards and downwards to access all content on display pages that contain multiple lines of information

Display pages

Home page

The home page is used to deliver comfort-related information as well as modify the indoor temperature.

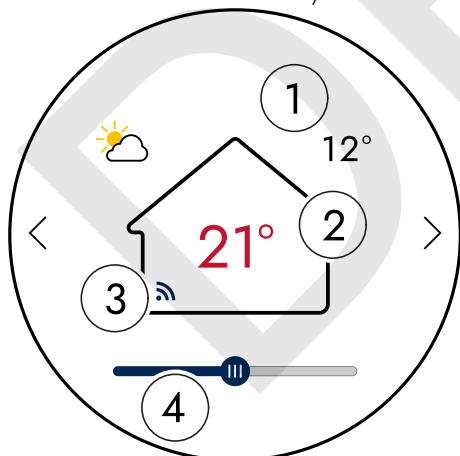

1. Outdoor temperature, as read by the outdoor temperature sensor.
2. Current indoor temperature. Requires installation of an indoor temperature sensor.
3. Symbol showing the status of the Wi-Fi connection.
4. Slider for adjusting the indoor temperature. To show the slider, press the house icon. The value inside the house shows the set value.

Domestic hot water

The page for domestic hot water is used to deliver information about the hot water production as well as modify the hot water temperature.

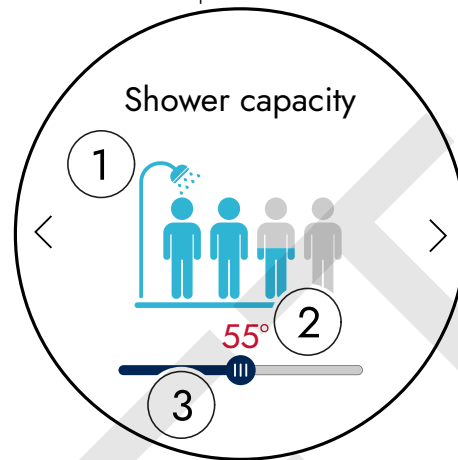

1. Indicator that shows the amount of remaining hot water. When the set temperature is reached, all characters are colored blue. The number of characters depend on the requested hot water temperature.
2. Set value for the domestic hot water.
3. Slider for adjusting the hot water temperature. To show the slider, press the shower icon. The value above the slider shows the set value

Comfort and scheduling

The comfort and scheduling page is used to activate and control functions that accommodate needs that are outside of the heat pump's default operational modes.

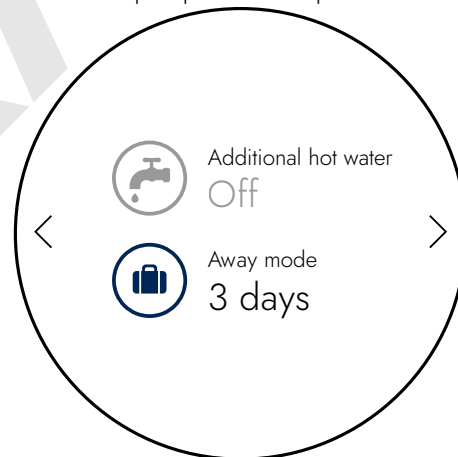

Extra hot water increases the hot water production for instances where additional hot water is desired.



NOTE

Depending on the current operating mode of the unit, turning on **Extra hot water** may also temporarily activate the immersion heater.

Away mode is a scheduling function that is useful when leaving the house for longer periods of time. When the away mode is activated, the heat pump lowers the indoor temperature and the hot water production.

Extra settings

The settings page has a number of subpages that are used to retrieve product information, change display options, and configure heat pump performance.

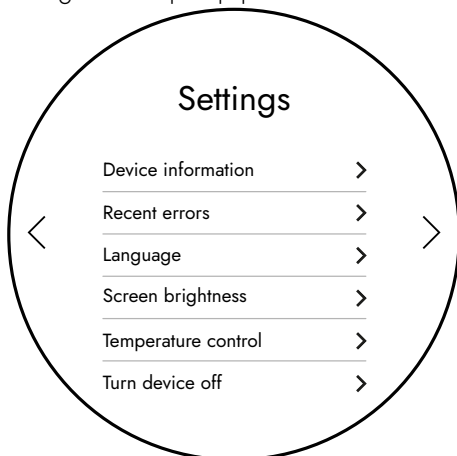

Shutting down the unit

The unit is shut down through **Extra settings > Turn device off**.

8 SERVICE

General

! CAUTION

Maintenance and servicing must be performed by persons with sufficient knowledge about the task.

Maintenance

NOTE

The end user must be informed about necessary maintenance actions.

Service actions

Draining the product

In case of component changes or if the heat pump must be moved, it might be necessary to drain the product of water. Emptying the accumulator tank is done through the tank drain connection (QM13). If necessary, rotate the drain valve by pulling it upwards or downwards.

! CAUTION

Turn off the unit before draining the accumulator tank.

1. Remove the cap from the drain connection.

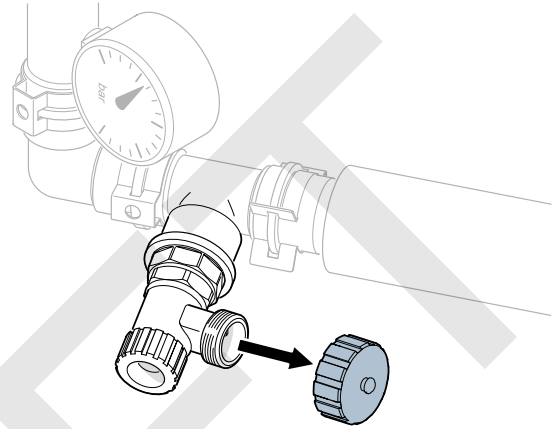

2. Attach a garden hose tap connector (1/2").

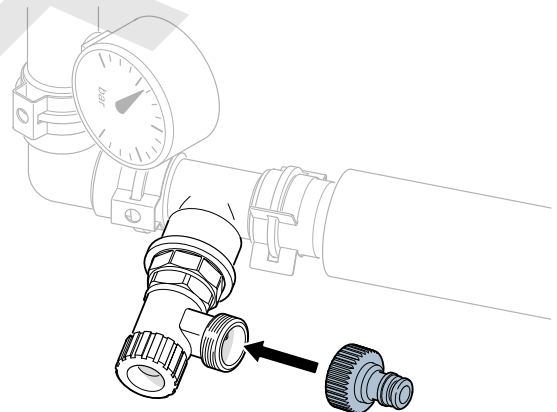
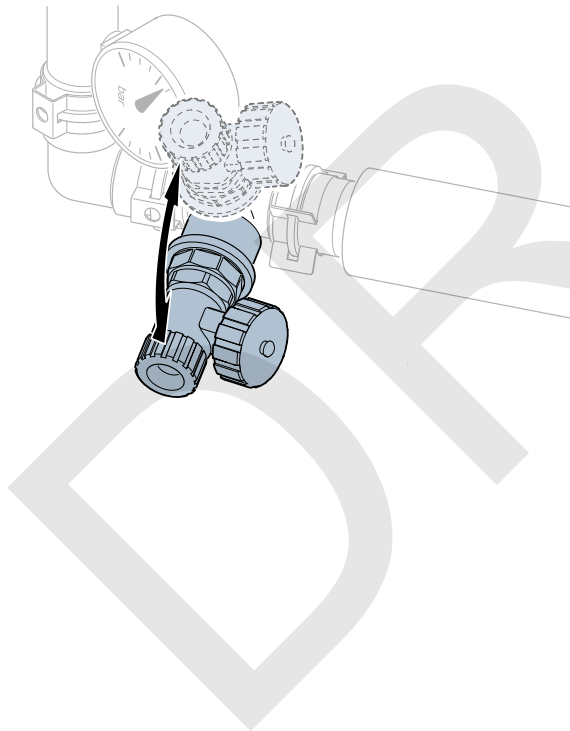

3. Attach a hose with a connector to the tap connector.

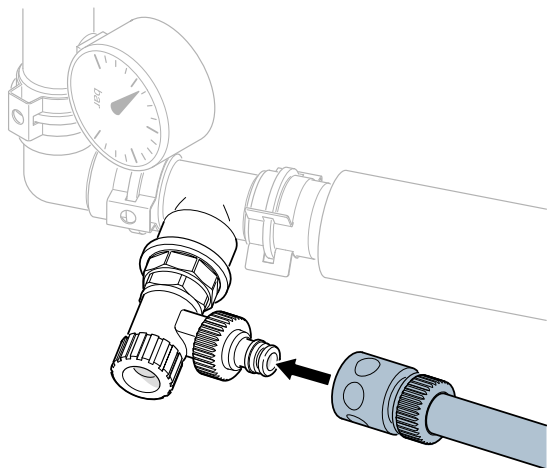

4. Open the drain connection by turning in counter-clockwise.

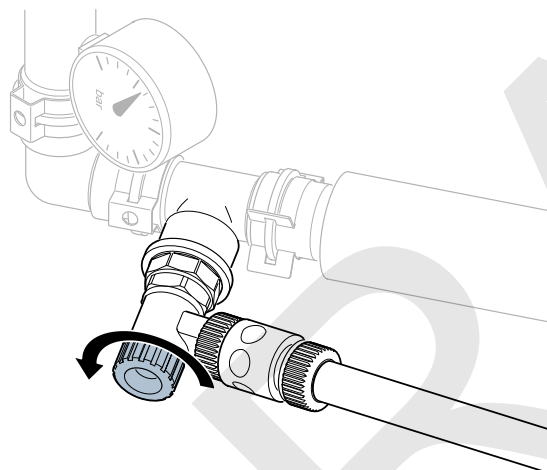

5. Open the bleed valve (QM22) for the accumulator tank.

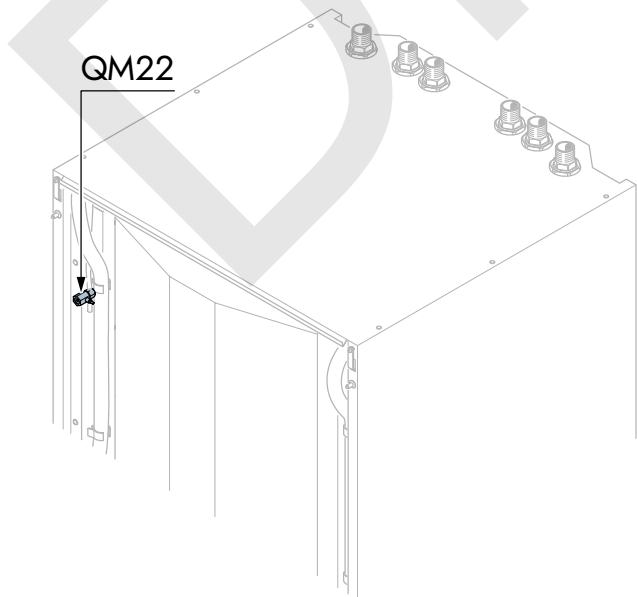

6. Remove the actuator from the diverting valve (QM10).
a) Pull the quick release lock (1) away from the actuator outlet.
b) Press the quick release ring (2).

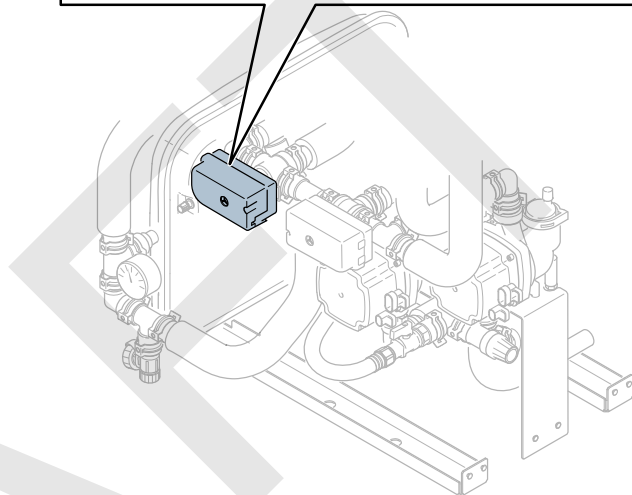
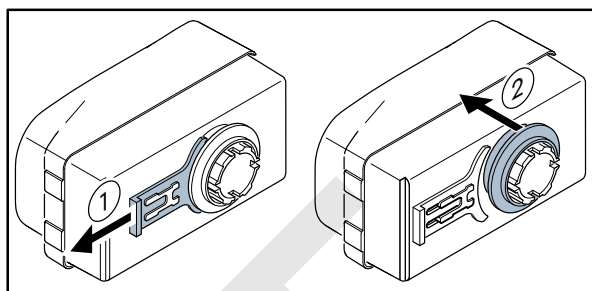

c) Remove the actuator (3).

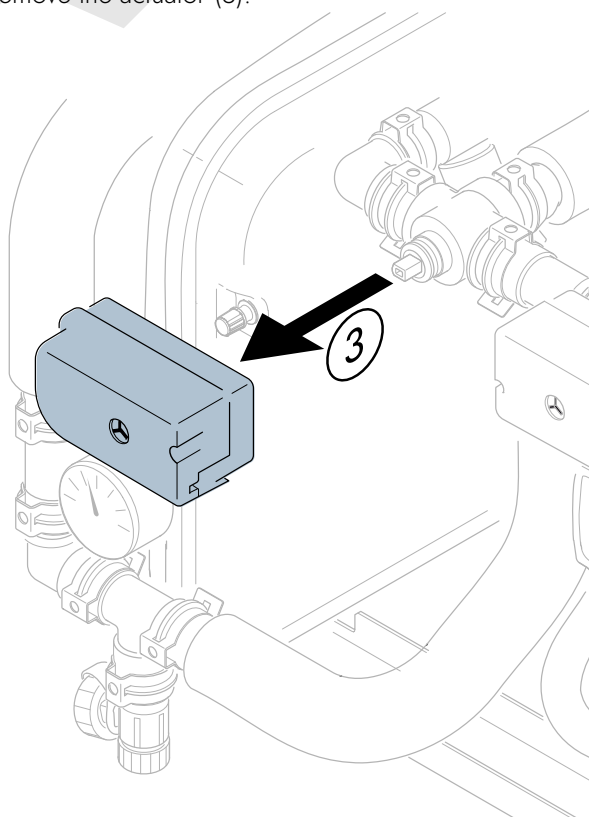

7. Turn the valve axle counter-clockwise (4) until the water starts flowing.

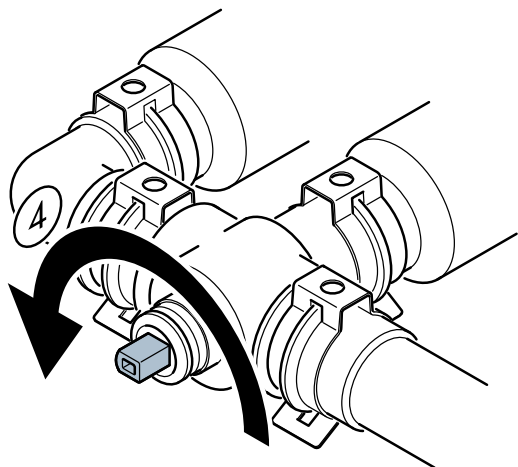

When water stops coming from the hose, restore the product to its original state.

- Close the drain connection
- Close the bleed valve
- Restore the diverting valve axle to the original position
- Reattach the actuator
- Remove the hose connectors
- Reattach the cap.

9 TROUBLESHOOTING

Before troubleshooting

If the system does not inform about an active fault, check the following components before troubleshooting:

WARNING

The incoming supply electricity must be isolated at the safety switch by or under the supervision of a trained electrician in the event that corrective action is needed to address faults that call for work inside screwed hatches.

- Power supply.
- Group and main fuses of the property.
- Residual current device (RCD).
- Internal fuses (F01–F08).
- Safety temperature limiter (FQ10).

Low room temperature during heating

The room temperature is undesirably low when a heating demand is active

Closed thermostats

- Ensure that the thermostats are fully open. Keep in mind that individual thermostats can be turned down if a certain space needs to be cooler than the set target temperature.

Incorrect operational mode

- If operational mode **Auto** is active, set a higher value for setting **Stop heating**.
- If operational mode **Manual** is active, select **Heating**.
 - a) If selecting **Heating** is insufficient, enable setting **Allow additional heat**.

Too low target settings for automatic heat control

- Set a higher value for the offset heating curve.
 - a) If the room temperature is only insufficient in cold weather, increase the **Heating curve** setting with one step.

Wrong prioritisation set for heating

- Increase the time for heating prioritisation. Increasing the time for heating prioritisation reduces the time for hot water production, which can give insufficient hot water production.

Operational mode **Extra** combined with increased hot water consumption

- Set operational mode **Eco** or **Normal**.

Vacation mode is active

- Turn off **Vacation mode** through the Qvantumapp.

Room heating is controlled by external input

- Check external switches.

Heating medium pump(s) have stopped

- Check speed settings for circulation pumps.

Air in the distribution system

- Purge the distribution system.

Shut-off valve for heating medium supply is closed

- Open the shut-off valve for heating medium supply.

Insufficient value set for electrical addition

- Use the Qvantum app and increase the setting for **Max electrical addition**.

Incorrect setting for max installed electrical power

- If possible, use the Qvantum app and increase the setting for **Max installed electrical power**.

High room temperature during heating

The room temperature is undesirably high when a heating demand is active

Too high target settings for automatic heat control

- Set a lower value for the offset heating curve.
 - a) If the room temperature is only too high in cold weather, decrease the **Heating curve** setting with one step.

Heating is controlled by external input

- Check external switches.

Insufficient hot water production

Lack of domestic hot water

Hot water demand is temporarily higher than in normal operation

- Temporarily increase the hot water production through setting **Comfort and scheduling** > **Extra hot water**.

Too low target temperature for hot water production

- Through display page **Domestic hot water**, increase the target temperature for hot water production.

Faulty pipe installation

- Verify that the pipes for the hot and cold water connections are installed correctly.

The external mixing valve is set too low

- If present, verify that the mixing valve is set correctly.

Increased hot water consumption

- Wait until the domestic hot water reaches a sufficient temperature. The hot water production can be temporarily increased by activating operational mode **Extra** for hot water capacity.

Low system pressure

Insufficient amount of water in the heating system

- Refill the water in the heating system.

DRAFT

10 TECHNICAL SPECIFICATIONS

Dimensions

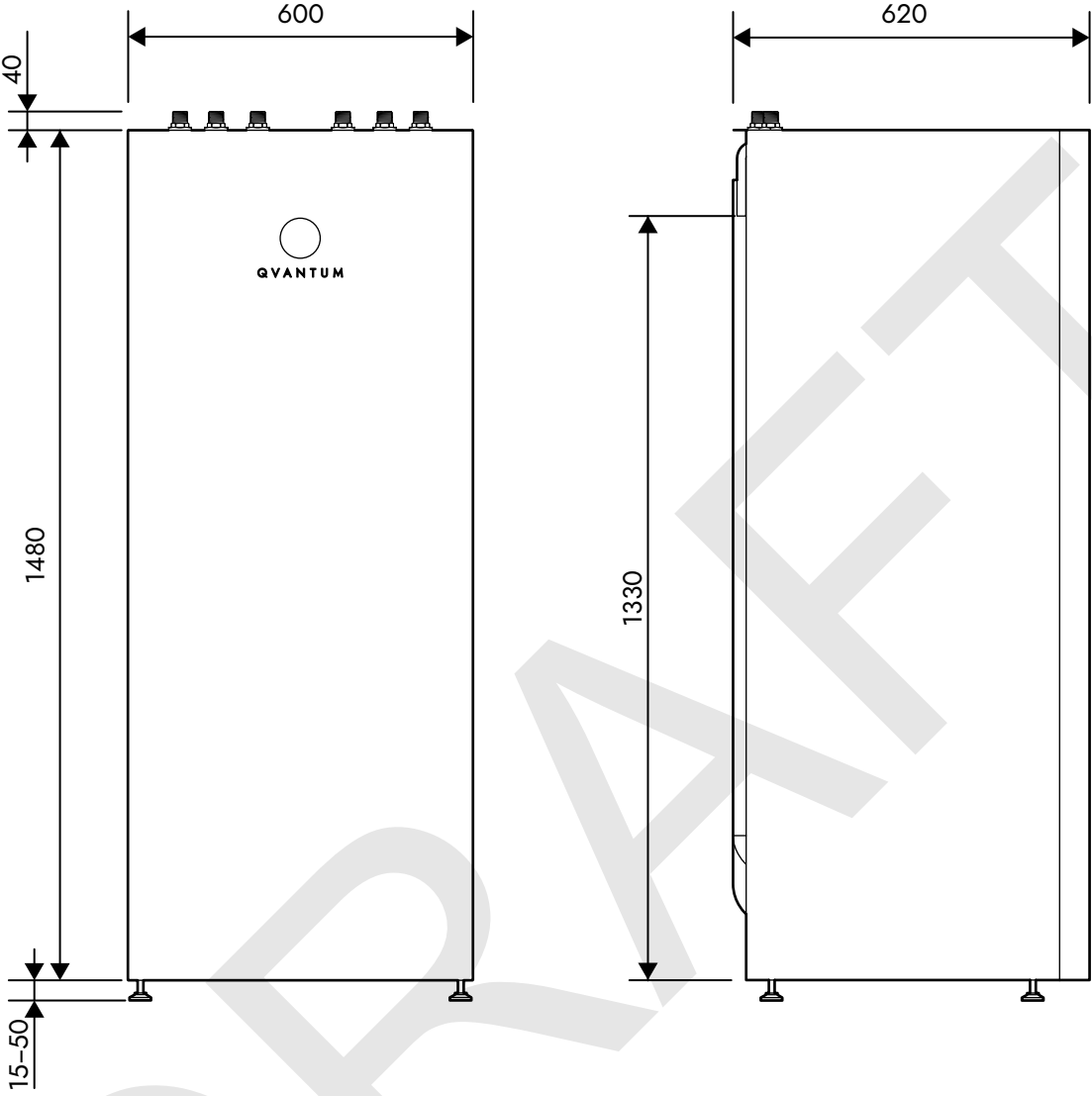

Technical data

MODEL		QH-175
Heating medium circuit		
Buffer tank volume	l	175
Operating pressure, safety valve ¹	MPa/bar	0.3 / 3
Max recommended temperature, supply line	°C	64
Max pressure, buffer tank	l/s	0.3 / 3
Operational range	°C	25 - 75
Hot water		
Plate heat exchanger volume	l	?
Operating pressure, safety valve	MPa (bar)	0.3 / 3
Amount of domestic hot water (40 °C) EN16147 ²	l	235
Electrical data		
Rated voltage	V	400V 3N ~ 50Hz / 230V 1N ~ 50Hz
Max power immersion heater	kW	5.0 (1+2+2)
Maximum electric consumption, 3x400V / 1x230V	A	9 / 23
Recommended fuse, 3x400V / 1x230V	A	10 / 25
Enclosure class		IP 21
Connection dimensions		
Distribution system, external thread		DN20
Cold water, external thread		DN20
Hot water, external thread		DN20
Heat pump, external thread		DN20
Weight and dimensions		
Weight, empty / filled	kg	110 / 285
W x D x H	mm	600 x 620 x 1480
Service clearance height	mm	1715
Misc.		
Part no.		9330064

¹ The safety valve is not present in the unit. Install a safety valve externally if the unit is installed as a standalone electric heating boiler.

² At tap flow rate 10 l/min.

Index

A

Accessories [7](#)

B

Before installing
Transport [6](#)

C

Components
Electrical box [8](#)
Fuses [12](#)
Overview [8](#)

E

Electrical connections [13](#)
1x230V [13](#)
3x400V [13](#)
Power connection [13](#)
Sensors [14](#)
Indoor temperature sensor [15](#)
Outdoor temperature sensor [15](#)
Electrical installation [12](#)
Access
Electrical box [12](#)
Heat pump unit [14](#)
Safety temperature limiter [15](#)
Environmental information [4](#)

F

Front cover removal [7](#)
Disconnecting the display unit [7](#)

I

Important information
Environmental information [4](#)
Product labels [4](#)
Safety [4](#)
Serial number [4](#)
Installation area [6](#)
Setup dimensions [6](#)

O

Operating principle [9](#)

P

Pipe connections [10](#)
Measurements and dimensions [10](#)
Pipe installation [9](#)
Cold and domestic hot water [10](#)
Distribution system [10](#)

S

Safety temperature limiter [15](#)
Setup dimensions [6](#)

Shutting down the unit [19](#)
Supplied components [6](#)
System volume [9](#)

T

Technical specifications [25](#)
Dimensions [25](#)
Technical data [26](#)
Transport [6](#)
Troubleshooting [23](#)
Before troubleshooting [23](#)

QCH EN 2423-1



2345

This publication presents information that was valid at the time of publishing.
Quantum reserves the right to make changes without prior notification.
Subject to possible printing errors.
©2024 Quantum Energi AB

DRAFT

HEAT PUMPS FOR SUSTAINABLE CITIES

WE CHANGE THE WAY THE CITIES OF EUROPE ARE HEATED

Quantum, founded in Sweden in 1993, develops high-quality heat pumps for individual buildings and innovative heat pump-based solutions for densely populated areas to enable everybody to benefit from emission free heating and cooling. The company has deep knowledge in both heat pump technology and energy systems engineering and works in close collaboration with engineering consultants, installers, project developers and utilities.

Quantum Energi AB

Ji-te gatan 7, 265 38 Åstorp – Sweden | quantum.com



Q V A N T U M