

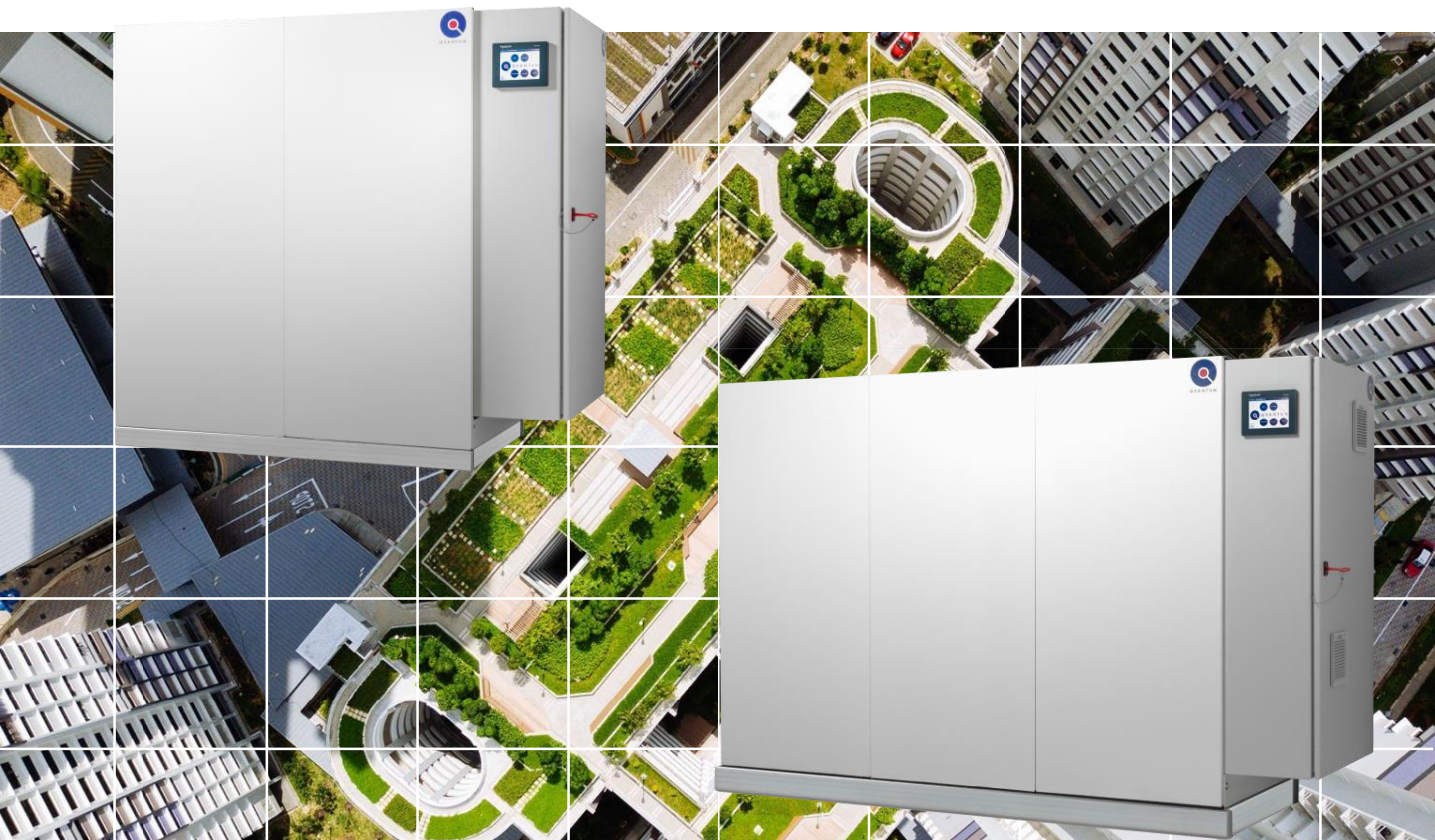

Q V A N T U M

HEAT PUMPS FOR SUSTAINABLE CITIES

QVANTUM KVP



Heat pump/chiller with free cooling functionality

Q48-192KVP

Air/Water

41 – 163 kW



High efficiency

Economizer

Compact design

Flexible installation

Quantum KVP – High efficient air sourced heat pump/chiller

GENERAL

Quantum Series KVP is effective when there is a simultaneous heating and cooling demand. It discharges the surplus of either heating or cooling with an outdoor air unit. The outdoor air unit could also be replaced by for example a borehole solution.

V.I.P. VAPOR INJECTION POWER VIA ECONOMIZER & LIQUID INJECTION POWER

Quantum KVP heat pumps are equipped with both vapor injection and liquid injection where it mainly operates with V.I.P. which means that the generated heat output capacity increases at the same time as the coefficient of performance, COP, also increases. The gas temperature is lowered during the compression process, which means that a higher supply temperature can be achieved.

- In step 1, refrigerant gas from the evaporator is sucked in the same way as in a normal cooling circuit.
- In step 2, the gas compressed in step 1 is supplemented with new cold gas from the economizer (sub cooler).

The unit can deliver up to 65°C supply temperature.

Thus, V.I.P. via economizer results in:

- higher supply temperature can be achieved
- the heat capacity increases by higher supply temperature
- increased efficiency and COP are obtained

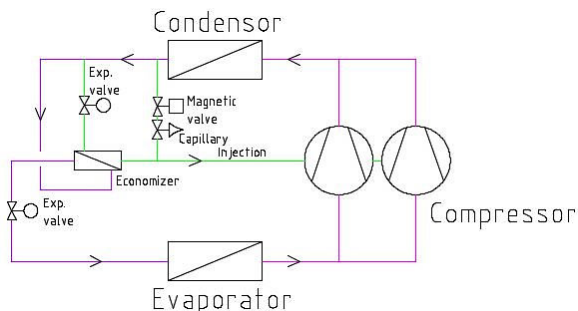

Figure 1. Principal refrigerant circuit with V.I.P. Vapor & Liquid Injection Power.

Liquid Injection Power (L.I.P.) is used to protect the compressor from overheating at very low evaporating temperatures. The transition between V.I.P. and L.I.P. is automatic based on set values from the factory.

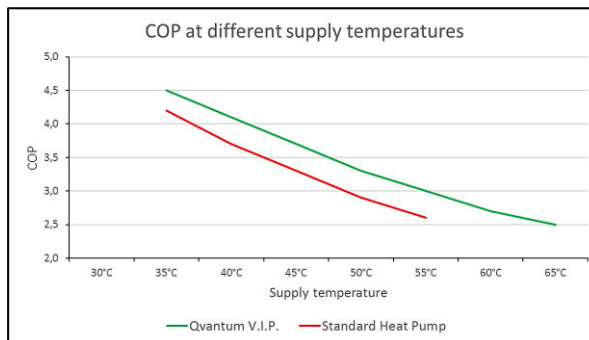

Figure 2. Change in heat factor as a function of flow temperature.

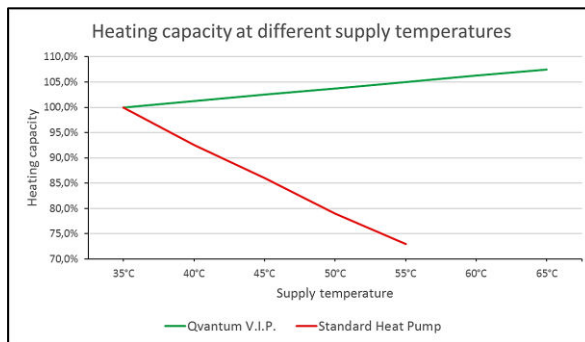

Figure 3. Change in heat output as a function of flow temperature.

DEFROSTING

The KVP uses an effective defrosting system which makes it possible to make use of the heat pump even when the temperature is low. It is only active when needed, when the moist in the air freezes on the aircoil fins.

The fin thickness is 0,25 mm and the fin pitch is 5 mm. The 5 mm fin pitch will allow long intervals between defrosting.

PLACEMENT

The outdoor air unit is placed where it is most appropriate. The standard design of the brine system is dimensioned for a total length of 2 x 25 meters between the indoor heat pump unit and the outdoor air coil. If longer distances are desired, the capacity of the brine pump can be increased.

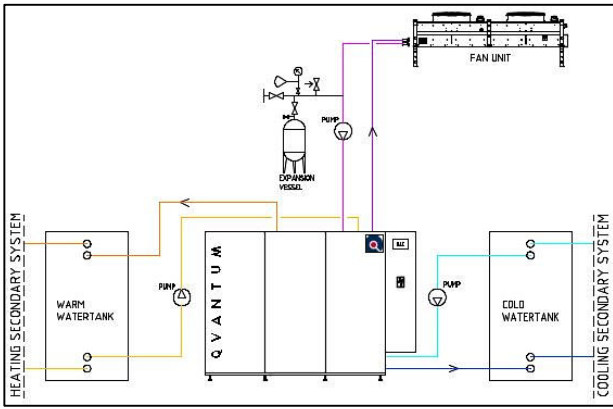

Figure 4. Principal connection between the heat pump, warm and cold tank and the fan unit.

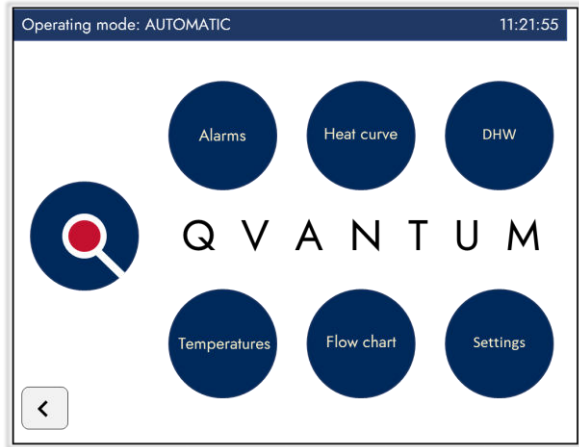

Figure 6. 5,7" panel display

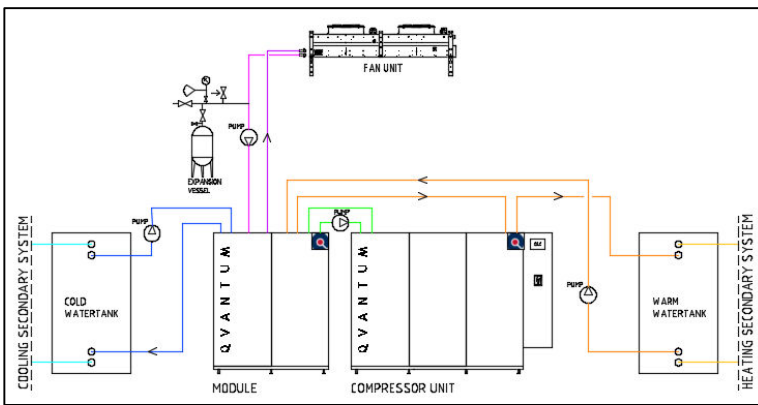

Figure 5. Principal connection between the heat pump, warm and cold tank, the fan unit and the module.

QVANTUM QLC CONTROL SYSTEM

Quantum KVP is equipped with the QLC control system as standard. QLC stands for Quantum Logic Controller. The unit is controlled and operated via the principal of liquid condensation or solid/half solid condensation. All control parameters, such as outdoor temperature compensated set-point curve for supply, hot water temperature, and auxiliary heat, are set via the self-instructing control system. Required protection and safety features are built into the QLC control system.

The system is managed via a 5,7" panel mounted in the heat pump. All parameters can be set via the panel. The panel displays a dynamic flow chart panel with all temperatures and operating modes measured and controlled. The QLC control system also logs temperatures and events, which facilitates setup and analysis.

The system communicates via Modbus. Modbus TCP is standard. The system also has a webserver which allows the QLC control system to communicate with a web browser on a PC or cell phone.

As an option, the unit can be equipped with a display that allows for dynamic flow images and extended network functionality. The temperature to the heating system is controlled according to the selected outdoor temperature compensated curve. Hot water preparation, if such a function is required, takes place via a switching valve.

In bivalent systems, the control system switches on additional heat when necessary and after a time delay. The auxiliary heat can be selected to "take over" the hot water preparation as the first step and thereby release power from the heat pump to the heating system.

The QLC control system can control up to 8 heat pumps in sequence with automatic operating time equalization between the different heat pumps. The QLC control system is configured at commissioning depending on the selected system solution and type and number of heat pumps.

The heat pump can be configured for control via an overlaying external control system if required. Set points can be changed via Modbus so that the controller's regulators are set by the master controller. It is also possible to configure the system so that the heat pump is fully controlled by the overlaying external control system. In this case, the QLC control system is used only for alarm and protection functions.

E.g., Temperatures readable via Modbus *)

- 1: Heat pump heat carrier - in
- 2: Heat pump heat carrier - out
- 3: Heat pump hot gas temperature
- 4: Heat pump brine - in
- 5: Heat pump brine - out
- 6: Radiator circuit supply
- 7: Outdoor temperature

*) See Modbus description for complete information

All relay outputs are also readable. You can thus transfer the operating status of compressors, pumps, fans, etc. which are controlled via the heat pump.

Set points for hot water temperature and control curve for radiator circuit can be read and adjusted. From the expansion valve control unit, the current evaporating temperature, pressure, overheating, the degree of opening of the expansion valve can be monitored via Modbus.

ELECTRONIC EXPANSION VALVE

Quantum KVP heat pumps are equipped with two electronic expansion valves, one for the evaporator circuit and the other for the economizer circuit.

The expansion valves have their own electronic control unit with display that shows evaporation pressure, temperature, overheating etc. for the two circuits. Via Modbus, these variables can be transferred to an overlaying control system.

REFRIGERANT

All Quantum KVP heat pumps uses R-407C refrigerant.

BRINE CIRCUIT

Quantum KVP has pipes filled with a mixture of water and antifreeze between the outdoor air battery and the compressor unit/defrosting tank. In most cases, water + ethylene glycol (45%) is used, but a mixture of water and methanol can also be used. Ethanol and propylene glycol cannot be used as anti-freeze agents.

PIPE CONNECTIONS

Q48KVP has top and back side connections, see drawing Q-KVP-48-001.

Q65 – 96KVP have top and back side

connections, see drawing Q-KVP-65-96-001

Q123 – 192KVP have back side connections, see drawings Q-KVP-123-144-001 and Q-KVP-123-144-001.

CONSTRUCTION

The unit is built on a robust stand of galvanized square tubes and covered with an effective sound-absorbing casing, consisting of powder-coated plates with sound-absorbing material inside. The top plate is made of patterned aluminum. The top and bottom are also covered with sound-absorbing material. The stand rests on adjustable rubber feet.

ACCESS

The unit is constructed so that all components inside the heat pump are easily available by removing the cover plates, both for maintenance and replacement.

OPTIONS

The following options are available:

- Larger model of brine pump due to increased distance between heat pump unit and air coil.
- Connecting QLC to network.
- Electrical cabinet mounted on the left side of the unit, seen from the front.

EQUIPMENT

Compressor

All KVP units are equipped with fully hermetic scroll compressors, 3-phase 400V.

Q48KVP is equipped with 1 compressor.

Q65-96KVP are equipped with 2 compressors.

Q123KVP and Q144KVP are equipped with 3 compressors.

Q162KVP and Q192KVP are equipped with 4 compressors.

Refrigerant circuit

Q48-144KVP are equipped with 1 refrigerant circuit.

Q162KVP and Q192KVP are equipped with 2 refrigerant circuits.

Heat exchanger

- The evaporator is a stainless steel, brazed heat exchanger, insulated with Armaflex insulation.
- The condenser is a stainless steel, brazed heat exchanger.
- Economizer is a brazed plate heat exchanger in stainless steel.
- The heat exchanger for cooling is a stainless steel, brazed heat exchanger, insulated with Armaflex insulation.
- Hot gas heat exchanger (option) is a brazed plate heat exchanger in stainless steel.
- Defrosting/heat dump heat exchanger is a stainless steel, brazed heat exchanger.

Circulation pumps

- Pump for condensor, external mounting
- Pump for evaporator, external mounting
- Pump for fan unit, external mounting
- Pump for primary cooling circuit, internal mounting
- Pump for secondary cooling circuit, external mounting
- Pump for defrosting/heat dump circuit, internal mounting

Control valve

- Control valve for defrosting/heat dump circuit, internal mounting
- Control valve for circulation over brine circuit, internal mounting
- Control valve for primary cooling circuit, internal mounting

Module

For the models Q123-193KVP the heat exchangers, circulation pumps and control valves for cooling and defrosting/heat dump are placed in a separate module.

Refrigerant circuit

- Drying filter
- Sight glass with moisture indicator
- Solenoid valve with equipment for liquid injection power (L.I.P.)
- Electronic expansion valves for refrigerant circuit and economizer (V.I.P.)
- Pressure/temperature sensor
- Control equipment with display (Modbus) for the main circuit
- Pressure transmitter
- High- and low-pressure switch, manual reset
- Service valves for refrigerant pressure measurement
- Rotalock valves
- Pressure protection equipment, high and low pressure

TESTING

The units are test run and calibrated under design conditions using ClimaCheck.

TECHNICAL DATA

See separate document "Quantum KVP – Technical data" for more information.



Solution and Heat Pump Experts

Qvantum was founded 1993 with a vision to develop innovative high quality heat pumps. Today Qvantum continues on this path developing the solutions needed for decarbonization of our cities.

Qvantum is also a company with leading experts in the design of the next generation (5th) district heating and cooling solutions for dense urban areas.

By combining these competence areas, Qvantum can provide solutions that will make it easier for Engineering consultants, Installers, Project developers and Utilities, to decarbonize the heating and cooling of our cities.

