

## ***Installation and maintenance***

### ***30-stage electric boilers***

***400V3~: EP 450 TL | EP 510 TL | EP 540 TL | EP 600 TL | EP 700 TL***

***690V3~: EP 600 TL | EP 750 TL***



# Contents

<b>Notes</b> .....	<b>3</b>
<b>Safety and handling</b> .....	<b>4</b>
<b>Function</b> .....	<b>5</b>
<b>The menu, the standard</b> .....	<b>6</b>
<b>Menus -with outdoor temperature compensation (UTK)</b> .....	<b>7</b>
<b>Operation and maintenance</b> .....	<b>8</b>
Control panel	
<b>Operation and maintenance</b> .....	<b>9</b>
Start - first operation	
Installation menu	
<b>Operating menu, adjustment menu</b> .....	<b>10</b>
<b>Adjustment menu -with outdoor temperature compensation (UTK)</b> .....	<b>11</b>
<b>Installation menu</b> .....	<b>12</b>
<b>Information on the menu</b> .....	<b>14</b>
<b>General menu</b> .....	<b>15</b>
<b>Operation and maintenance</b> .....	<b>16</b>
Restart after power cut	
Power connection	
Delayed power connection after power cut	
Quick increase/reduction	
Load guard	
PEC function	
Safety valves	
Over temperature protection	
Maintenance	
Cooling fan	
Draining	
Action in the event of a risk of freezing	
<b>Venting - water pressure</b> .....	<b>17</b>
<b>Checking temperature switches</b> .....	<b>17</b>
<b>Pressure guard(s) - option</b> .....	<b>17</b>
High pressure guard	
Low pressure guard	
Ajustment	
<b>Operation and maintenance</b> .....	<b>17</b>
<b>Alarm - warning - information</b> .....	<b>18</b>
Red indicator flashing - Alarm	
Yellow indicator flashing - warning	
Green indicator flashing - information	
<b>Alarm - load-break switches and safety guards...</b>	<b>20</b>
Boiler shares safety equipment	
<b>Alarm - load-break switches and safety guards...</b>	<b>21</b>
Load-break switch	
Pressure guard(s) - option	
Reset	

<b>General</b> .....	<b>22</b>
Water quality	
Flow requirement	
<b>Pipe installation</b> .....	<b>23</b>
Open system	
Closed system	
<b>Electrical installation</b> .....	<b>24</b>
Operating voltage	
Power supply	
Power supply to external unit	
Circulation pump	
External alarm indication	
Pressure guards -safety equipment	
Load guard	
Reconnection	
Electrical installation	
External blocking	
External stage control — 0 - 10 V, 0 - 5 V or 4 - 20 mA	
External setpoint — 0 - 10 V, 0 - 5 V or 4 - 20 mA	
0 - 10 V output signal of connected power	
0 - 10 V output signal of boiler temperature	
Outdoor temperature sensor - boiler with UTK	
Alternative heating - boiler with UTK	
<b>Control circuit</b> .....	<b>28</b>
<b>Power circuit</b> .....	<b>30</b>
<b>Technical Data</b> .....	<b>32</b>
<b>Troubleshooting</b> .....	<b>36</b>
Irregular operation	
Tables for temperature sensors	
<b>Components</b> .....	<b>37</b>
<b>Option</b> .....	<b>38</b>

# Notes

*To be completed when the boiler is installed!*

	400V 3~				690V 3~		
Type item no.	EP 450 TL 6955	EP 510 TL 6956	EP 540 TL 6957	EP 600 TL 6958	EP 700 TL 6960	EP 600 TL 4738	EP 750 TL 6961
Serial number					Date of installation		
Plumber							
Tel							
Electrician							
Tel							
Other,							

## Settings

<b>Installed power</b>	kW	<b>Number of stages</b>	
Load guard	<input type="checkbox"/> yes <input type="checkbox"/> no	Primary transformer	(xxxx/5)
Main fuse	A	Margin	A
Current limit	A		

External temperature set-point	<input type="checkbox"/> no	<input type="checkbox"/> 0 - 10 V	<input type="checkbox"/> 0 - 5 V	<input type="checkbox"/> 4 - 20 mA
External stage limit	<input type="checkbox"/> no	<input type="checkbox"/> 0 - 10 V	<input type="checkbox"/> 0 - 5 V	<input type="checkbox"/> 4 - 20 mA
Max. limit		°C	Min. limit	°C

## UTK - heating curve

P1 $T_{outside} = 20\text{ °C}$	°C	P7 $T_{outside} = -10\text{ °C}$	°C
P2 $T_{outside} = 15\text{ °C}$	°C	P8 $T_{outside} = -15\text{ °C}$	°C
P3 $T_{outside} = 10\text{ °C}$	°C	P9 $T_{outside} = -20\text{ °C}$	°C
P4 $T_{outside} = 5\text{ °C}$	°C	P10 $T_{outside} = -25\text{ °C}$	°C
P5 $T_{outside} = \pm 0\text{ °C}$	°C	P11 $T_{outside} = -30\text{ °C}$	°C
P6 $T_{outside} = -5\text{ °C}$	°C	Temperature adjustment	°C

# Safety and handling

- Read these instructions carefully before installation and operation! Keep the instructions in the boiler!
- Check that the boiler has not been damaged during transport. Report any transport damage to the carrier.
- Check that the delivery is complete.
- All installation must be performed by an authorised person in accordance with the existing regulations.
- Risk of electric shock. Never leave the boiler door open!
- Never disable the safety equipment!
- The boiler must never be switched off electrically unless the heating system is full and the boiler vented.
- Correct installation in combination with correct adjustment and continuous service will produce high operational reliability and good heating economy.
- The boiler must not be modified, changed or converted in any way.
- Only authorised persons may work on the boiler.
- Disconnect the boiler from the power supply and lock the switches before service/repairs.
- Never carry out maintenance work/ service on pressure-bearing parts when they are pressurised.
- The boiler may not be used by children or people with physical or mental impairments. Nor by children/people who lack knowledge of the boiler. Children may not play with the boiler or connected accessories.
- Always contact your installation engineer for service.
- The type and manufacturing number of the boiler must always be specified when contacting Värmebaronen, see the boiler's rating plate.
- Värmebaronen AB reserves the right to change the specification, in accordance with its policy of continuous improvement and development, without prior notice.
- Subject to amendments and printing and proofreading errors. Illustrations may differ from the actual product.

The following icons are used in these instructions to indicate important information:



*Information that is important for optimum operation.*



*Tells you what you should or should not do to avoid personal injury.*



*Tells you what you should or should not do to avoid a component, the boiler, a process or the environment being damaged or destroyed.*



*Electrical hazard!*

## Function

**Electric boilers for heating systems or industrial processes.**

**The boiler's power is divided into 30 power stages.**

**The boilers' control range is 20-95°C.**

**The output of the boilers can be restricted to one power stage.**

**The electric boiler is CE marked as a unit and is classified as pressure equipment according to Directive 2014/68/EU, Article 4(3).**

**The electric boiler can be supplied with factory-fitted safety equipment, reviewed by accredited body according to EN 12828.**

**Final examination, under national laws, that the electric boiler has the necessary safety equipment shall be carried out by an accredited body when assessing the monitoring interval for the electric boiler.**

**The factory-fitted safety equipment contains safety valve(s), high-pressure guard and automatic vent valves.**

**Double circulation pumps and flow guards are not required. The boiler can cope with zero flow from a safety perspective.**

**A steam-collecting vessel is not required. The safety valves are fitted directly on the boiler's safety pipe.**

### Safety

The boilers have load-break switches which are acted on via shunt release by the boiler's thermal relay and pressure guards. The boilers do not restart automatically after a power cut.

### Operational reliability

The boilers are fitted with float switches and leakage current measurement, which provides an early indication of any faults in the immersion heaters, so that faults can rapidly be dealt with, without unplanned stoppages.

### Alarm indication

Alarms are indicated on the boiler's control panel. Connection for external indication of a buzzer alarm, alternating potential-free relay output.

### Stainless steel immersion heaters

The immersion heaters are in stainless steel SS2353 with brass heads.

### Pump maintenance operation

Connection for a circulation pump with a pump maintenance operation function.

### External stage and power control

Connection for external blocking, 0 - 5 V, 0 - 10 V and 4 - 20 mA control of power.

### External temperature setpoint

Connection for external setpoint in the form of 0 - 5 V, 0 - 10 V and 4 - 20 mA signal.

### Output signal for present power and temperature

0 - 10 V signals for the number of power stages connected and boiler temperature.

### Load guard

Protects the main fuses; secondary transformers are supplied with the boiler.

### Reconnection after power cut

Power is reconnected after a power cut according to recommendation.

### Power supply to external unit

Fused 230 V~ output for supply to an external unit.

### Aluminium and copper

To facilitate installation, the boilers are fitted with terminals that make it possible to connect both aluminium and copper cables. No splicing from aluminium is required.

### Outdoor temperature compensator, option

Controls the boiler temperature in relation to the outdoor temperature via an outdoor sensor.

### Cooling fan

The boilers may be fitted with cooling fan(s) with air filters for use in areas with high temperatures or dusty atmospheres. Fan, included in EP 450, -510 and 700 TL.

### Series connection for greater power, option

If more power is needed, two boilers can be controlled in series

### Temperature control in secondary circuit, option

When used with, for example, a heat exchanger, the temperature in the secondary circuit can control the boiler.

# The menu, the standard

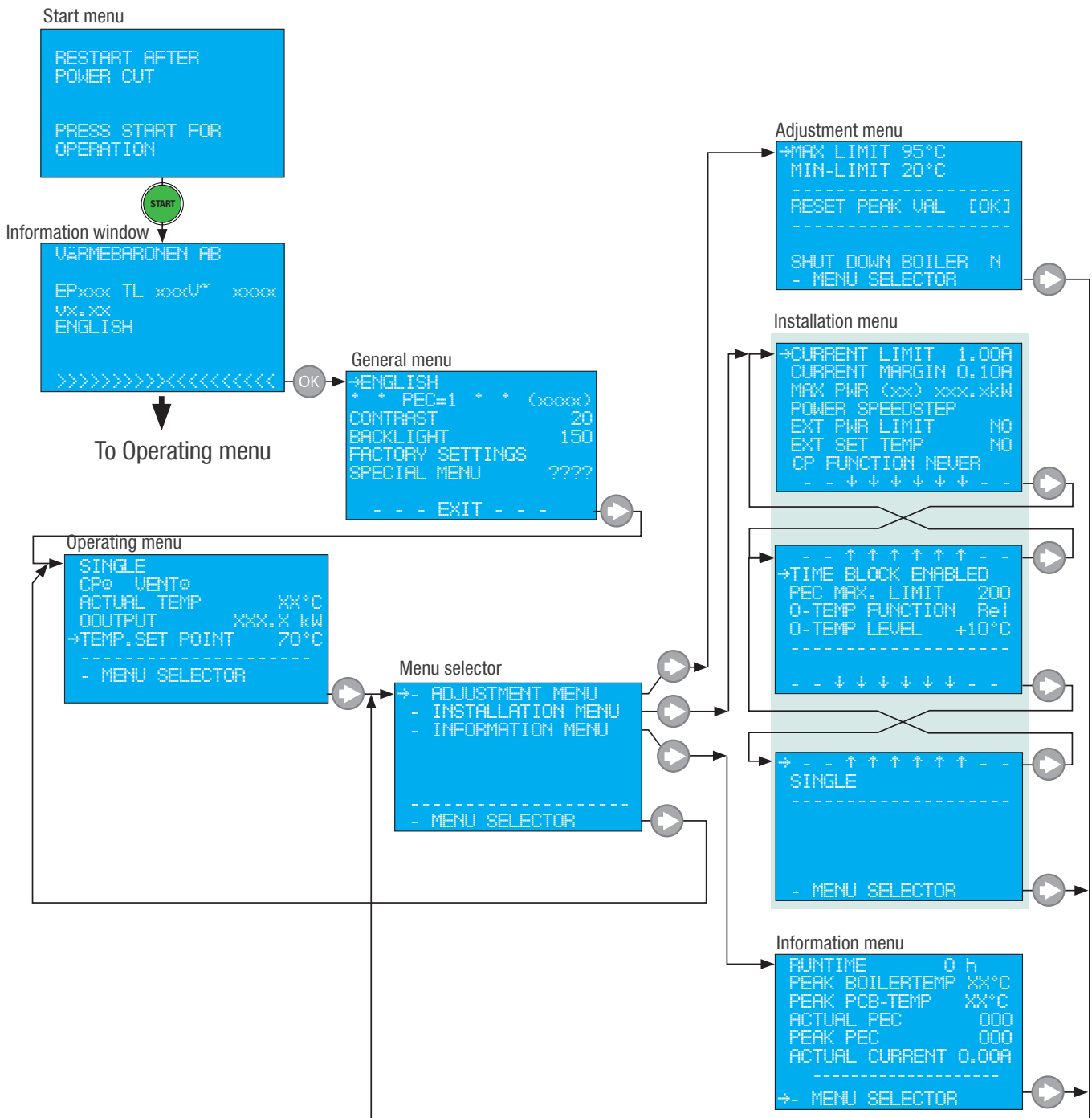

When electronics are switched on, the Start Menu is displayed. If **OK** the information window is pressed when the arrows on the bottom row point towards the middle, the General Menu will be displayed. If is not affected, **OK** the Operating Menu is opened, which displays the boiler temperature, connected power and temperature set point.

A screen with the Menu selector is opened by moving to the bottom line with **↓** and pressing **→** there. From this you can access the Adjustment Menu, Installation Menu and Information Menu, or return to the Operating Menu. The procedure is the same in the other menus.

An index arrow to the left on the line indicates that it contains information that can be changed.  
**↑** / **↓** moves the index arrow between the lines.  
**→** selects the current line.  
 Change the content with **↑** / **↓**.  
 Leave the line with **OK**.

Displayed as follows:  
**→ - - - E X I T - - -** To OPERATING MENU with **→**.  
**→ - - ↑ ↑ ↑ ↑ ↑ - -** To the previous window with **→**.  
**→ - - ↓ ↓ ↓ ↓ ↓ - -** To the following window with **→**.  
**→ MENU SELECTOR** To MENU SELECTOR with **→**.

# Menus - with outdoor temperature compensation (UTK)



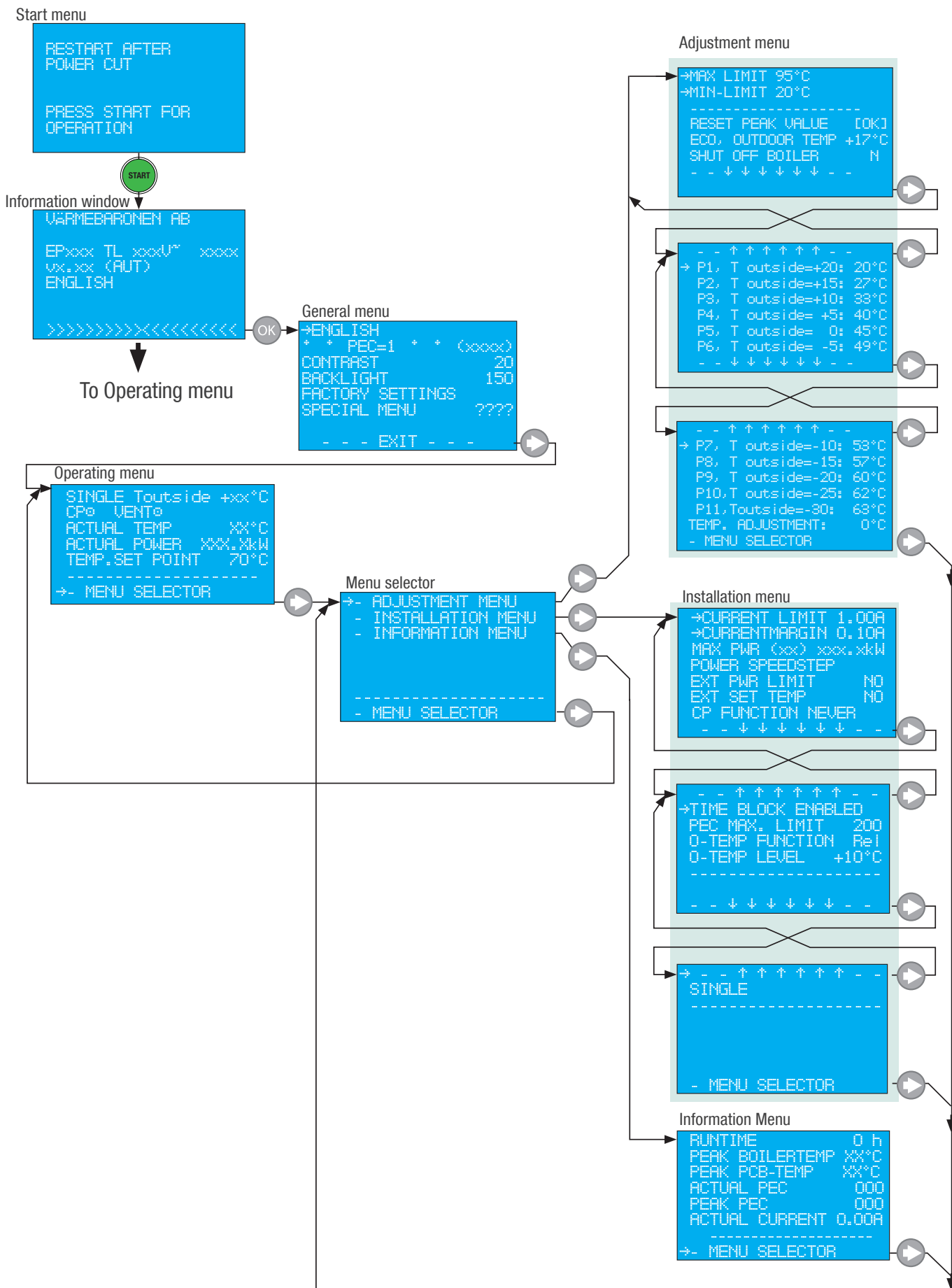





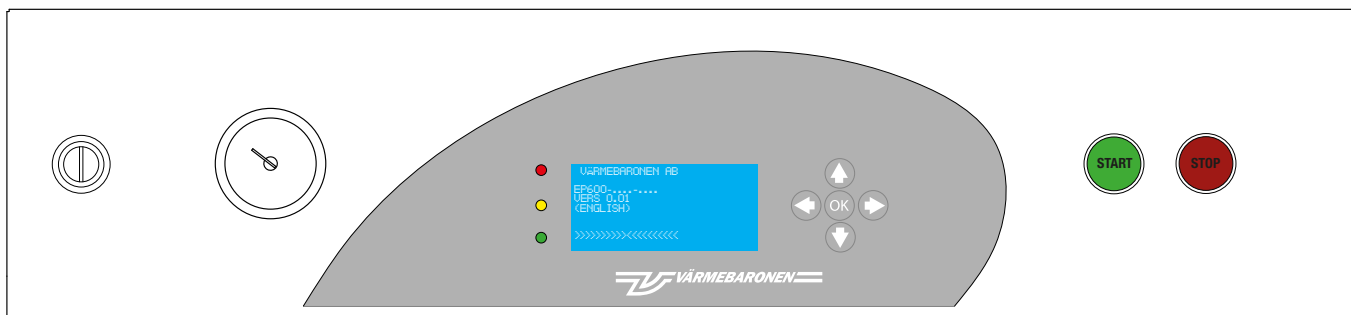



Outdoor temperature compensator, UTK, is an option!



# Operation and maintenance

## Control panel



-  red indication  
Off: normal.  
Flashing: serious fault.  
The display shows the cause when  is pressed.
-  yellow indication  
Off: normal.  
Flashing: warning.  
The display shows the cause when  is pressed.
-  green indication  
Off: normal.  
Flashing: something is preventing power increase/  
decrease.  
The display shows the cause when  is pressed.
-  Used to restart the boiler after a power cut.
-  Breaks the power supply to the boiler by tripping the boiler circuit breaker. Voltage to the operating circuit is not broken!
-  moves the index arrow up between rows of editable content. Set/change the content with an UP/DOWN arrow. Parameters with a large setting range have an “acceleration” function when the button has been pressed for a while.
-  moves the index arrow up between rows of editable content. Set/change the content with an UP/DOWN arrow. Parameters with a large setting range have an “acceleration” function when the button has been pressed for a while.
-  Press the RIGHT arrow to select the highlighted line. Set/change the content with the UP/DOWN arrow.
-  -
-  Confirms a change and jumps back to the current menu. Changes made take immediate effect when OK is pressed.
- DisplayShows status, alarms etc. The display returns to the Operating menu a minute after any button has been pressed.
- ManometerShows the water pressure in the boiler/  
heating system.



# Operation and maintenance

**Before switching on and first operation the boiler, all operating conditions must be met, check:**

**Power cables' connections; tighten them.**

**That the boiler and heating system are full of water and vented and that the air vents are open so that they can let air out.**

**That all necessary valves are open.**

**That the circulation pump is working and the flow direction is correct.**

**That any safety valves are working.**

**That no tools or similar have been left behind the busbar system.**

**That safety equipment is working as intended.**

## Start - first operation

Switch on the power to the boiler, follow the instructions in the window. Windows will not appear if the manual restart function is bypassed, see "Restart after power cut".

```
RESTART AFTER
POWER CUT
```

```
PRESS START FOR
OPERATION
```

If the conditions are correct, this window will appear for a short time. The information varies slightly depending on the equipment of the boiler.

```
VÄRMEBARONEN AB
```

```
EPxxx xxxU*   xxx
xx.xx (AUT)
ENGLISH
```

```
>>>>>>>>X<<<<<<<<<
```

The Operating Menu is then displayed. The information varies slightly with the boiler's equipment.

```
SINGLE T outside xx°C
CPo VENTo
ACTUALTEMP XX°C
OUTPUT XXX.X kW
→TEMP.SET POINT  xx°C
```

```
- MENU SELECTOR
```

If the bottom row switches between displaying this, the cause is displayed when **OK** is held down, see "Alarm - warning - information".

```
- MENU SELECTOR
```

```
PRESS OK FOR INFO
```

**When the boiler is first operated, the following parameters must be checked/adjusted. More information is available under 'Menus'. Note the settings in 'Notes'**

## Installation menu

Load guard

```
→CURRENT LIMIT  x.xxA
```

The setting values are calculated.

```
→MARGIN  x.xxA
```

Output limiting

```
→MAX POWER (30)xxx.xkW
```

Number of power stages the boiler should work with.

External stage limitation

```
→EXT PWR LIMIT  NO
```

Potential-free blocking, 0-5V, 0-10V or 4-20 mA.

External temperature setpoint

```
→EXT SET TEMP  NO
```

0-5V, 0-10V or 4-20 mA.

Circulation pump

```
→CP FUNCTION  NEVER
```

Operating options, NEVER, AUTO, ALWAYS or ECO (only with UTK, optional).

Delayed reconnection

```
→DELAY ENABLED
```

Reconnection after power cut

Over temperature

```
→O-TEMP FUNCTION:  ReI
```

```
→O-TEMP LEVEL:  +10°C
```

Adjustment menu

Max and min setpoints

```
→MAX SET LIMIT  95°C
```

Limits of the range for setting the boiler's temperature setpoint.

```
→MIN SET LIMIT  20°C
```

Setting of heat curve

```
- - ↑↑↑↑↑↑ - -
→ P1, T outside=+20: 20°C
P2, T outside=+15: 27°C
P3, T outside=+10: 33°C
```

Boiler with OTC.

```
- - ↑↑↑↑↑↑ - -
→ P7, T outside=-10: 53°C 45°C
P8, T outside=-15: 57°C 49°C
P9, T outside=-20: 60°C
P10, T outside=-25: 62°C
P11, T outside=-30: 63°C
TEMP. ADJUSTMENT: 0°C
- MENU SELECTOR
```

Operating menu

Boiler temperature, setpoint

```
→SET TEMP  70°C
```

Standard boiler.

Pressure guards

If the boiler was supplied with safety equipment, see 'Alarm - load-break switches and safety guards', High-pressure guard and Low-pressure guard.

# Operating menu, Adjustment menu

## Operating menu

```
SINGLE T outside XX°C
CPⓈ VENTⓈ
ACTUAL TEMP      XX°C
ACTUAL POWER    000.0kW
→TEMP SET VALUE 70°C
-----
- MENU SELECTOR
```

```
SINGLE
```

“SINGLE”, information, changes with series operation, option.

```
CPⓈ VENTⓈ
```

CPⓈ : pump in operation.

CP : flashes, pump paused.

See 'CP Function' in the installation menu.

VENTⓈ : cooling fan in operation.

VENT : cooling fan paused.

```
ACTUAL TEMP      XX°C
```

Information, current boiler temperature.

```
ACTUAL POWER    000.0kW
```

Information, current connected power.

```
→TEMP SET VALUE 70°C
```

Setting, desired boiler temperature, 20 - 95°C, setpoint.

The setting range is affected by max. and min. limits.

## Adjustment menu

```
→MAX SET LIMIT   95°C
→MIN SET LIMIT   20°C
-----
RESET PEAK VALUE [OK]
-----
SHUT DOWN BOILER N
- MENU SELECTOR
```

```
→MAX SET LIMIT   95°C
```

```
→MIN SET LIMIT   20°C
```

Max. and min. limits of the range for setting the boiler's temperature setpoint.

Max. limit: 55 - 105°C.

Min. limit: 20 - 50°C.

```
RESET PEAK VAL. [OK]
```

Resetting all the high values in the information menu.

```
SHUT DOWN BOILER N
```

Set boiler to standby mode (switched off).

# Adjustment menu - with outdoor temperature compensation (UTK)

## Adjustment menu - boiler with UTK - Window one

```

->MAX SET LIMIT 95°C
->MIN SET LIMIT 20°C
-----
RESET PEAK VALUE [OK]
-----
ECO, OUTDOOR TEMP+17°C
SHUT DOWN BOILER N
- - ↓ ↓ ↓ ↓ ↓ ↓ - -
    
```

```

->MAX SET LIMIT 95°C
->MIN SET LIMIT 20°C
    
```

Setting range for temperature setpoint.

Max. limit: 50 - 105°C.  
Min. limit: 20 - 45°C.

```

RESET PEAK VAL. [OK]
    
```

Resetting the values in the information menu.

```

ECO, OUTDOOR TEMP+17°C
    
```

Lowest temperature at which no heating is required. All boiler power disconnected, the circulation pump is stopped.

**Alternative** `->CP FUNCTION ECO` in the **Installation menu must be selected for the ECO function to be active and for temperature setting to be carried out**

```

SHUT DOWN BOILER N
    
```

Set boiler in standby position (switched off).

### Window two

Setpoint at outdoor

temperature:

- 20°C →
- 15°C →
- 10°C →
- 5°C →
- 0°C →
- 5°C →

```

- - ↑ ↑ ↑ ↑ ↑ ↑ - -
P1, T outside=+20: 20°C
P2, T outside=+15: 27°C
P3, T outside=+10: 33°C
P4, T outside= +5: 40°C
P5, T outside= 0: 45°C
P6, T outside= -5: 49°C
- - ↓ ↓ ↓ ↓ ↓ ↓ - -
    
```

### Window three

Setpoint at outdoor

temperature:

- 10°C →
- 15°C →
- 20°C →
- 25°C →
- 30°C →

```

- - ↑ ↑ ↑ ↑ ↑ ↑ - -
P7, T outside=-10: 53°C
P8, T outside=-15: 57°C
P9, T outside=-20: 60°C
P10, T outside=-25: 62°C
P11, T outside=-30: 63°C
TEMP. ADJUSTMENT: 0°C
- MENU SELECTOR
    
```

```

->TEMP. ADJUSTMENT 0°C
    
```

Alternative temperature, against normal temperature, +/- adjustment of setpoint, parallel displacement. The change is affected by a contact function connected to terminal block J2, see point 32 "Control circuit".

## Heating curve

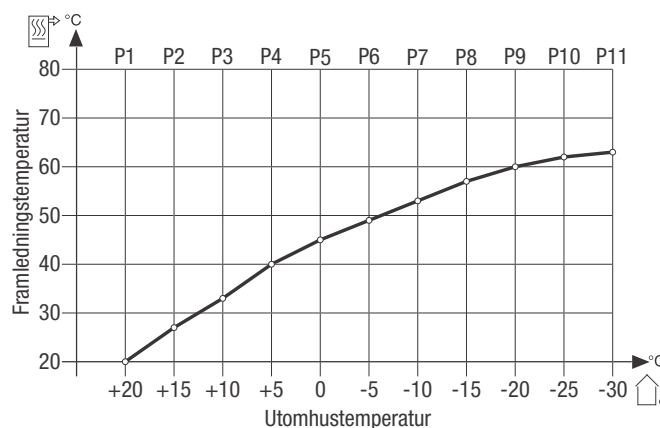

Each setpoint, P1 - P11, is adjustable over the range 20 - 80°C

# Installation menu

## Window one

```

->CURRENT LIMIT      x.xxA
CURRENT MARGIN      x.xxA
MAX PWR (3D)       xxx.xkW
POWER SPEEDSTEP
EXT PWR LIMIT      NO
EXT SET TEMP       NO
CP FUNCTION NEVER
- - ↓ ↓ ↓ ↓ ↓ ↓ - -
    
```

## Load switch

```

->CURRENT LIMIT      x.xxA
->CURRENT MARGIN     x.xxA
    
```

Setting values are calculated, for example:

Main fuse: 800 A

Current transformer: 1000/5

Boiler, EP 510 HT: 17 kW/stage/24.5 A. See "Technical data".

Current transformer's conversion ratio:

$$\frac{1000}{5} = 200$$

Current limit

$$\frac{\text{main fuse current transformer's conversion ratio}}{\text{conversion ratio}} = \frac{800}{A200} = 4$$

Margin

$$\frac{\text{size of power stage in ampere current}}{\text{transformer's conversion ratio}} = \frac{24.5 \text{ A}}{200} = 0.12$$

```

->MAX PWR (3D) 600.0kW
    
```

Selection of the power with which the boiler is to operate. The figures in brackets show the number of stages.

```

->POWER SPEEDSTEP
    
```

Quick increase/reduction of power in connection with checks and acceleration of the delay when it is active. If the delay is active, the display shows

```

->SPEEDING TIME BLOCK
    
```

Release the button and press it again if you want quick increase/decrease.

```

->EXT PWR LIMIT      NO
    
```

Stage limit with external signal, 0-100% of selected power, "Max. POWER".

NO: internal limit.

0-5V: limit with 0 - 5 V.

0-10V: limit with 0 - 10 V or potential-free blocking.

4-20mA: limit with 4 - 20 mA.

```

->EXT SET TEMP       NO
    
```

Temperature setpoint via external signal.

NO: internal setpoint.

0-5V: nominal value with 0 - 5 V (0-170° C).

0-10V: nominal value with 0 - 10 V (0-170° C).

4-20mA: setpoint with 4-20 mA (0 - 170°C).

```

->CP FUNCTION        NEVER
    
```

Operating method for circulation pump supplied with power by the boiler:

NEVER: no pump operation/pump switched off

AUTO: The pump starts before power is connected and stops one minute after all power has stepped out. If the pump is not in operation, it is run once daily. In the event of over temperature, the pump starts and is in operation until the over temperature situation ends, even if all power is disconnected.

ALWAYS: Pump always in operation.

ECO: Only with UTK, option. Pump stop with maintenance operation, when the outdoor temperature meets the set temperature according to `ECO, OUTDOOR TEMP +17°C` in the Adjustment menu

# Installation menu

## Window two

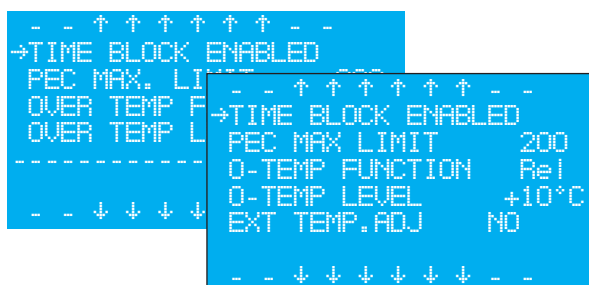

→TIME BLOCK ENABLED

Limits power connection after a power cut which has lasted longer than three minutes. See 'Delayed power connection' under 'Operation and maintenance', options:  
 Switched off: no function.  
 Activated: delayed power connection.

→PEC MAX. LIMIT 200

Limit value, 0 - 500 quality factor, for PEC function alarm.

→O-TEMP FUNCTION Rel

→O-TEMP LEVEL +10°C

Over temperature function:  
 Rel: over temperature, 5 - 15°C, relative to setpoint.  
 Abs: absolute value for over temperature , 105 - 106°C  
 Temperature level for the over temperature function, range:  
 5 - 15°C when relative to setpoint is selected.  
 35 - 105°C for absolute temperature.

with UTK →Ext. TEMP.ADJ NO

Will the function be used with closing or open contact,  
 alternative: No  
               J2→0 open  
               J2→C closed

## Window three



→SINGLE

Information, changes with series operation, option.

# Information menu

```
RUNTIME                0h
PEAK BOLERTEMP        xx°C
PEAK PCB-TEMP         xx°C
ACTUAL PEC             xxx
PEAK PEC              xxx
ACTUAL CURRENT        x.xx A
-----
->MENU SELECTOR
```

```
RUNTIME                0h
```

The time in hours for which the electronics were powered.

```
PEAK BOLERTEMP        xx°C
```

The highest boiler temperature since the electronics were last switched on.

```
PEAK PCB-TEMP         xx°C
```

The highest temperature of the relay circuit board since the electronics were last switched on.

```
ACTUAL PEC             xxx
```

```
PEAK PEC              xxx
```

Result of leakage current measurement. The value, 1 - 500, is a quality factor, i.e. the lower the value, the better.

```
ACTUAL CURRENT        x.xx A
```

Requires that the load guard current transformers are installed. The current, measured by the secondary current transformer, 1 - 5 A is displayed. The actual current value is obtained by multiplying the read value by the primary transformer's conversion ratio.

# General menu

This menu is only available on start after the electronics have been without power.

Press **OK** when this screen is shown, while the arrows in the bottom row disappear towards the centre.



This window will then be displayed:

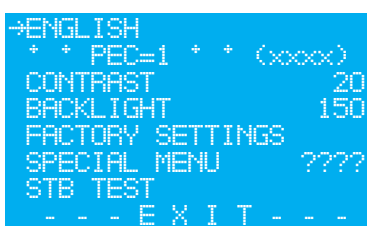

Language selection.  
Available languages: Swedish, English and German.



PEC = 1 PEC function active.  
PEC = 0 PEC function disabled.  
See 'HIGH PEC!' Under "Alarm-warning-information".  
The function is not reactivated automatically after a power cut.

(XXXX)  
Information to manufacturer.



Adjusting window contrast.



Adjustment of the backlighting of the window.



Reset to factory setting. YES = OK; NO = OTHER BUTTON



Manufacturer settings.



Only boiler with OTC function. Used to control the boiler's thermostats.

# Operation and maintenance

## Restart after power cut

The boiler does not restart automatically after a power cut. To start the boiler, follow the instructions in the display.

**Disconnection of the function must be evaluated in collaboration with the end-user and accepted by the accredited body that assesses the periodic monitoring of the boiler. See "Electrical installation".**

## Power connection

The boiler uses binary power increase. Thirty stages are achieved by connecting and disconnecting the power groups.

## Delayed power connection after power cut

Power connection can be time restricted after a power cut, that was longer than three minutes. When the delay is active, the green indicator on the control panel flashes. Information may be displayed in the display. The delay can be temporarily disabled. See the Installation menu.

## Quick increase/reduction

For quick increase/reduction, see the Installation menu.

## Load guard

The load guard protects the main fuses against overload by reducing the boiler's power. When the overload ceases, the power is reconnected.

## PEC function

By measuring the leakage current of the immersion heaters, the function gives an early indication of a possible fault in the immersion heaters and thus the possibility of action without unplanned downtime.

In some installations, the measurement may give incorrect readings, caused by other equipment connected to the installation's piping and electrical system providing vagabonded leak currents. If these currents get too high, the boiler switches off even if there is nothing wrong with the boiler. If this occurs, the PEC function should be turned off. A point on insulation testing of the immersion heaters should be added to the maintenance plan.

The break value for the PEC function is adjustable.

## Safety valves

To maintain the safety function, the heating system's safety valves must be operated regularly.

## Over temperature protection

As a supplement to the temperature switches, the control electronics have over-temperature protection whose aim is to prevent as far as possible temperature switches tripping. The protection disconnects all power in the event of a temporary temperature increase that may occur as a result of reduced flow following a pump stoppage.

## Maintenance



**After 500 hours of operation, the cable connections must be tightened with a torque wrench.**

Check the power cables' connections every 2 years.



**The control voltage is not broken by the load-break switches! External voltage may occur.**

## Cooling fan

The boiler cooling fan is equipped with an air filter, which is checked regularly. The interval depends on the environment in which the boiler is installed, but at least once a year.

## Draining



**Always cut the power to the boiler and lock the switches before the boiler water is drained!**

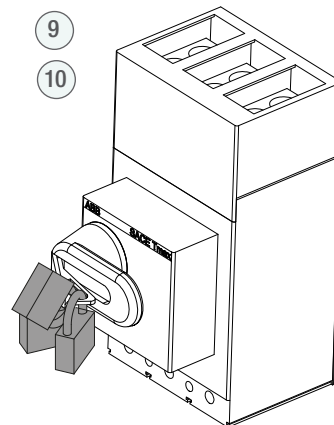

## Action in the event of a risk of freezing - frost protection



**The boiler must not be in operation if you suspect that any part of the heating system is frozen. Call an installation engineer!**

In severe cold, no part of the heating system must be turned off, because there is a risk of frost bursting. If the heating system must be switched off for long periods the system should be drained, or the heating system water can be mixed with maximum 30% glycol. When using a glycol mixture the boiler power is reduced, or the through flow in the boiler can be increased. If the heating system's water is mixed with glycol, it is important to check that the glycol contains a suitable quantity of corrosion-protection additive.



# Operation and maintenance

## Venting - water pressure

Regularly check that the water pressure is correct. Air may be left in the system for a while after installation, for which reason it should be vented a few more times.

**The pressure in a heating system varies with the temperature. Do not add water unnecessarily!**

## Checking temperature switches

Stop the flow through the boiler. Adjust the break temperature to 80°C, on the back of the thermostat.

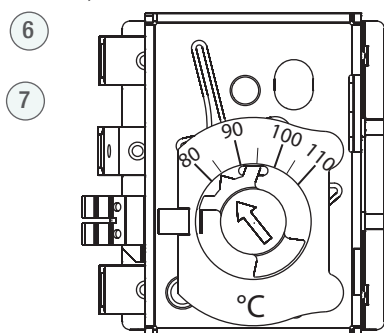

## Standard boiler:

Adjust the boiler temperature setpoint to 90°C. When the boiler temperature reaches the break temperature, the thermostats should be triggered together with the load break switch.

## Boiler with UTK:

Press the STOP button so that the load break switch trips. Reset the load break switch so that this window is displayed:



Press **OK** when the arrows on the bottom row point towards the middle, so that this window is displayed:

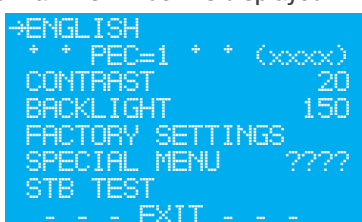

Activate the function by selecting:



This window will then be displayed:

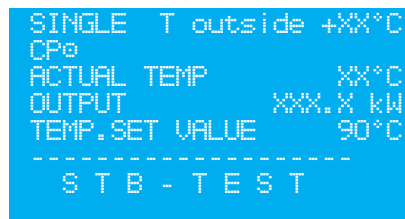

When the boiler temperature reaches the break temperature, the thermostats should be triggered together with the load break switch.

Do not forget to readjust the thermostat break temperature to 105°C when inspection is finished.

**The break temperature must not be set lower than the boiler temperature control's highest temperature!**

## Pressure guard(s) - option

### High pressure guard

Set so that the trigger pressure is between the boiler's normal operating pressure and the safety valves' opening pressure.

### Low pressure guard

Set so that the trigger pressure is slightly below the system pressure when the system is not heated.

## Adjustment

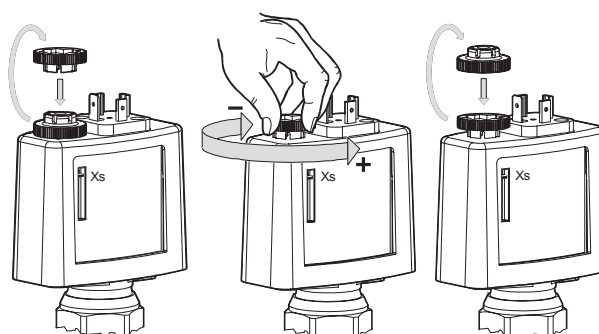

# Alarm - warning - information

At the same time as one of the indicators, red, yellow or green, is flashing, the bottom line of the window alternates between:

→- MENU SELECTOR

and

PRESS OK FOR INFO

When  is held down, the cause of the flashing indicator is shown.

## Red indicator flashing - Alarm

Buzzer alarm, output point 23 in "Control circuit". Requires action and manual reset.

R1 **TEMP SENSOR J1** (optional)

Pt100 boiler temperature sensor, point 29 in "Control circuit".  
Cause: Short-circuit, interruption or not connected.  
Action: Check, replace.

R2 **TEMP SENSOR J2** (optional)

Pt100 temperature sensor, point 30 in "Control circuit".  
Cause: Short-circuit, interruption or not connected.  
Action: Check, replace.

R3 **TEMP SENSOR J12**

Boiler temperature sensor, point 25 in "Control circuit".  
Cause: Short-circuit, interruption or not connected.  
Action: Check, replace.

R4 **TEMP SENSOR J14\*J9/3** (optional)

Secondary temperature sensor, point 28 in "Control circuit".  
Cause: Short-circuit, interruption or not connected.  
Action: Check, replace.

R5 **TEMP SENSOR J13** (optional)

Temperature sensor cooling fan, point 26 in 'Control circuit'.  
Cause: Short-circuit, interruption or not connected.  
Action: Check, replace.

R6 **TEMP SENSOR J3** (optional OTC)

Outdoor temperature sensor, point 33 in 'Control circuit'.  
Cause: Short-circuit, interruption or not connected.  
Action: Check, replace.

R7 **TEMP SENSOR, POWER**

Temperature sensor on power circuit board.  
Cause: Short-circuit or interruption.  
Action: Check, replace power circuit board

R8 **TEMP SENSOR, PANEL**

Temperature sensor on panel circuit board.  
Cause: Short-circuit or interruption.  
Action: Check, replace panel circuit board

R9 **HIGH PEC**

Reason: The PEC value is higher than the set break limit.  
The function measures the boiler's leakage current, in order to give an early indication of a possible electrical heating fault. In some systems, the measurement may give an incorrect measurement value, caused by vagabond leak currents in the plant's piping and electrical systems. See 'Operation and Maintenance, PEC function'.

Action: Check: Current and Highest PEC value in Information menu and PEC alarm limit in Installation menu. If the current PEC value is higher than the alarm limit, when no power is switched on, the cause is located outside the boiler. The alarm limit should then be raised approximately 50 units above the highest measured PEC value. The external leakage current should be identified and fixed. If the current PEC value is lower than the alarm limit, the fault may be in the boiler.

Check:

- Acknowledge the alarm by cutting the control voltage for 10 seconds.
- Allow the boiler to step in, while reading the current PEC value in the Information Menu.
- To determine which immersion heater is triggering the PEC alarm, each individual immersion heater in the power group must be insulation tested.
- If the boiler functions normally when power is switched on, without triggering PEC, the leakage current comes from an external source.

If the cause is not due to the boiler, the PEC function can be temporarily deactivated pending appropriate action.  
See "General Menu"

## Alarm - warning - information

R10

HIGH TEMP, POWER

Cause: High temperature of power circuit board,  $> 30^{\circ}\text{C}$ .

Action: Check the cause. Highest permitted ambient temperature is  $\leq 40^{\circ}\text{C}$ .

Check that the air filter of the cooling fan is not clogged.

R11

HIGH TEMP, PANEL

Cause: High temperature of panel circuit board.

Action: Check the cause. Permitted ambient temperature is  $\leq 40^{\circ}\text{C}$ . Check that the air filter of the cooling fan is not clogged.

R12

LOW WATER LEVEL, TANK

Cause: Low water level in the boiler.

Action: Check the cause, add water and vent the system.

R13

SEE MANUAL

Cause: A guard, high, low or temperature, has tripped without the power switch being tripped.

Action: Check the cause.

### Yellow indicator flashing - warning

Automatic reset when the cause has ceased.

Y1

PEC

Cause: Increasing PEC values, leak current.

Action: See R9, High PEC.

Y2

OVERTEMPERATURE

Cause: The boiler temperature is higher than the boiler temperature value.

Action: Check that the boiler has sufficient flow and that all necessary valves are open.

Check the setting for over temperature.

Y3

WATER LEVEL

Cause: Variations in the signal from the boiler's level sensor.

Action: Check the cause, add water and vent the system.

### Green indicator flashing - information

Something is preventing power increase/decrease. Automatic reset when the cause has ceased.

G1

DELAY

Cause: Delayed power connection after restart after power cut.

G2

LOAD GUARD

Cause: Load guard limits power increase/decrease.

G3

EXTERNAL ANALOGUE LIMIT

Cause: The boiler's power increase/decrease is limited by an external setpoint or stage limit.

G4

MIN/MAX LIMIT

Cause: The boiler temperature is max/min limited.

# Alarm - load-break switches and safety guards

**When a guard in the safety circuit is triggered, the display shows which guard or guards has/have been triggered.**

**The boiler's load-break switches are always triggered when a guard is triggered.**

**A buzzer alarm is issued from the boiler and a red indicator flashes on the boiler's panel.**

H pressure guards, high pressure guards, items 47 and 48.

L pressure guard, low pressure guard, item 49.

Thermostats, thermostats, items 6 and 7.

Switches, load-break switches, items 9 and 10.



**Always check the cause of a guard being triggered! If the guards are triggered repeatedly, the cause must be fixed!**

**Reset must take place in the order displayed in the window!**

Depending on the cause, the following may be displayed:

```
ACTUAL TEMP      70°C
SWITCH IN 0 POSITION
OR TRIPPED

PUT SWITCH IN ON
POSITION
```

```
ACTUAL TEMP      70°C
SWITCH & TEMP. GUARD
ARE TRIPPED

RESET 1.TEMP. GUARD
      2.LOAD-BREAK
```

```
ACTUAL TEMP      70°C
SWITCH & TEMP. GUARD
& H PRESSURE GUARD
ARE TRIPPED

RESET 1.TEMP. GUARD
      2.H-PRESSURE
      3.LOAD-BREAK
```

```
ACTUAL TEMP      70°C
SWITCH & TEMP. GUARD
& L PRESSURE GUARD
ARE TRIPPED

RESET 1.TEMP. GUARD
      2.L-PRESSURE
      3.LOAD-BREAK
```

```
ACTUAL TEMP      70°C
SWITCH &
H-PRESSURE GUARD
ARE TRIPPED

RESET 1.H-PRESSURE
      2.LOAD-BREAK
```

```
ACTUAL TEMP      70°C
SWITCH &
L-PRESSURE GUARD
ARE TRIPPED

RESET 1.L-PRESSURE
      2.LOAD-BREAK
```

```
ACTUAL TEMP      70°C
SWITCH &
& H-PRESSURE GUARD
& L-PRESSURE GUARD
ARE TRIPPED

RESET 1.H-PRESSURE
      2.L-PRESSURE
      3.LOAD-BREAK
```

```
ACTUAL TEMP      70°C
SWITCH & TEMP.GUARD
& H-PRESSURE GUARD &
L-PRESS. ARE TRIPPED

RESET 1.TEMP. GUARD
      2.L-PRESSURE
      3.H-PRESSURE
      4.LOAD-BREAK
```

## Boiler shares safety equipment

In a system in which the boiler shares safety equipment with other boilers in the system and this safety equipment is triggered, only this window can be displayed.

```
ACTUAL TEMP      70°C
SWITCH IN 0-POSITION
OR TRIPPED

PUT SWITCH IN ON-
POSITION
```

# Alarm - load-break switches and safety guards

## Load-break switch

When a guard trips the load-break switch will moved to "tripped" position. The switch is also tripped by the "STOP" button on the boiler panel. The switch is reset by turning the knob to "0 off" and then to "1 on".

The version of the switch is dependent on the boiler model. The procedure is not always the same!

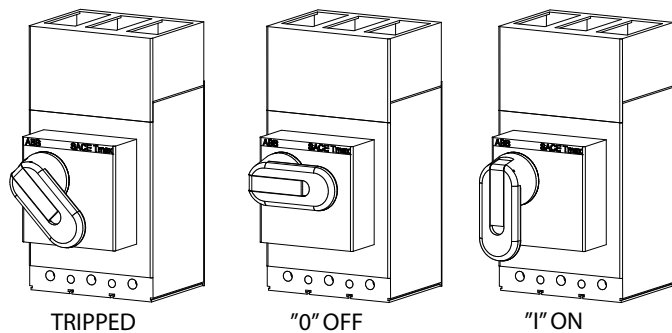

## Pressure guard(s) - option

### Reset

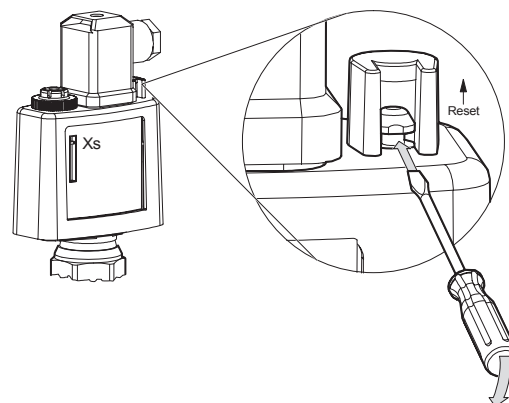

*The version of the switch is dependent on the model of boiler*

## Thermostats

The boiler's thermostats cut power to the boiler if the temperature exceeds 105°C. A thermostat is reset by pressing the button on the thermostat when the boiler temperature is below 80°C.

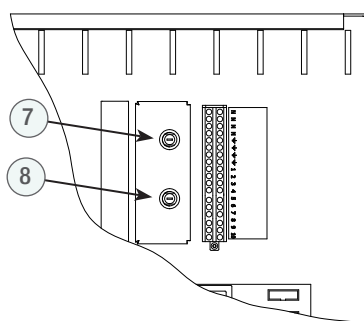

# General



**Installation must take place according to existing regulations and standards.**

**The boiler is placed standing indoors. The installation site shall be dimensioned for the weight of the water-filled boiler. The boiler can be placed directly on the floor level. The room should have a floor drain. At least 1 metre of free space must be provided in front of the boiler. Ensure there is sufficient ceiling height to allow the immersion heaters to be changed.**

**Adjust the foot bolts so that the boiler is horizontal.**

**Expansion system - The safety pipe, the boiler must be connected to an expansion system. Valves must be fitted between the boiler and the heating system. Pipes must be routed so that it is possible to open the front and remove the roof plate for service.**

**The boiler is not intended for use with oxygenated water. As frost protection, the water in the system may be mixed with maximum 30% glycol.**

**Heating systems can differ between countries due to climate, traditions and national regulations. In cases where the standards violate national regulations, the latter must be followed. Consider national and individual requirements.**

**Electric boiler supplied with safety equipment is reviewed by accredited body in accordance with EN 12828.**

**With factory-fitted safety equipment, the boiler can be installed without expansion tank.**

**Double circulation pumps and flow guards are not required. The boiler can cope with zero flow from a safety perspective.**

**A steam-collecting vessel is not required. The safety valves are fitted directly on the boiler's safety pipe.**

**Final examination, under national laws, that the electric boiler has the necessary safety equipment must be carried out by an accredited body when assessing the monitoring interval for the electric boiler.**

## Water quality

Tap water is usually classified from the point of view of hygiene. Good water classified on this basis is not automatically suitable for a heating system. To avoid problems, the water should be analysed from a technical point of view and any deviations from standard values should be adjusted. If the volume of the heating system is low, it can be filled with water that was not classified as good system water. When the water is heated, some oxygen and carbonic acid are emitted to the expansion tank or vent valves. The remainder will react with the metals in the system. This corrosion is generally insignificant. The system must be leakproof so that the water does not need to be replaced with new water and the water is not oxygenated during installation. In practice, it is impossible to protect large systems against leaks and oxygen admission. In such cases, an oxygen-consuming agent can be added so that there is always a slight surplus in the system. These agents often contain corrosion-limiting additives.

## Water quality - in respect of suitable tap water:

The alkalinity should exceed 60 mg/l to avoid corrosion.

Contents of carbonic acid over 25 mg/l increase the risk of corrosion.

Sulphate contents over 100 mg/l may accelerate corrosion. If the sulphate content is higher than the alkalinity, there is a risk of copper corrosion.

Hard water causes boiler scale and is not suitable in a heating system. The hardness must be approx. 5 - 6 dH°. Very soft water may cause corrosion damage.

Chloride contents over 100 mg/l make the water aggressive, particular when combined with lime deposits.

Low pH values may cause corrosion damage. The pH value should be 7.5 - 8.5.

The incidence of carbonic acid in combination with low pH and hardness values makes the water aggressive.

The water must not contain sludge or other impurities.

## Flow requirements

The boiler must have a constant, sufficiently high flow to function satisfactorily. The flow must be dimensioned so that it is within specified limits.

Insufficient water flow may result in the following:

- The difference between the temperature setting and the actual temperature achieved in the boiler increases.
- Irregular control with increased wear on the boiler's contactors, with reduced service life as a result.

Excessive water flow can result in the following:

- Vibrations in the immersion heaters with noise and reduced service life as a result.
- Unnecessary wear on the system's components.

Recommended flow produces a  $\Delta t$  of 10°C at the boiler's maximum power. See Technical data.

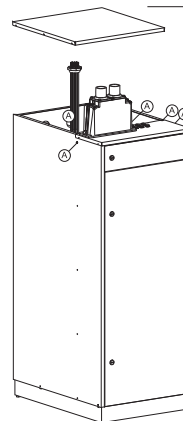

**Do not drill into the boiler's cover plates. Swarf can damage the boiler's electrical equipment!**  
**M6 bolts are available for fastening cable trays.**

**Minimum ceiling height, 2430 mm**

**Ⓐ = M6 bolts for fixing cable trays, etc.**

**Pipes, cable ducts, etc. may not be laid on the boiler's rear cover plate.**

## Pipe installation

*The figures shown are system principles. The actual system must be installed according to existing standards. Any additional equipment must be installed as indicated by the manufacturer of the product.*

### Open system

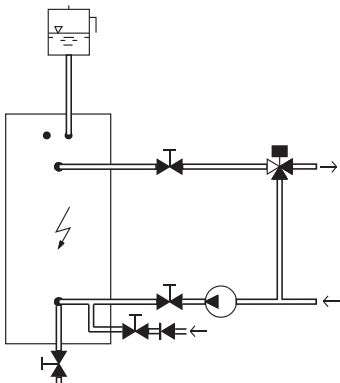

The boiler's safety line must be connected in an uninterrupted, un-closeable pitch to an expansion tank, installed at the highest point of the heating system.

Expansion vessels are dimensioned to accommodate changes in water volume due to heating and cooling.

Expansion vessels, safety pipes, aeration and overflow pipes must be installed such that they are protected against freezing.

To avoid oxygenation of the water, the distance between the heating system's highest point and the expansion tank must not be less than 2.5 metres.

Pressure height must exceed the pump's lowest static pressure on the low side.



**To avoid damage in the event of any blockage in the expansion system, the boiler should be fitted with a safety valve.**



**The air vent on the boiler's safety pipe must always be open. Otherwise, air collects in the top of the boiler, which leads to disruption as the float switch is triggered on account of insufficient water level.**

Closed system without a flash tank, >300 kW, ≤105°C



**The opening pressure of the safety valve is determined by the component in the system that tolerates the lowest pressure.**

Under SS EN 12828, the installation must include:

- At least one safety valve min DN 15, with sufficient blow-off capacity at the system's operating pressure.
- Two pressure guards, one with zero voltage release.
- Low pressure guard if there is a risk of boiling dry, alternative to level switch.
- Two thermostats, STB.
- Flow guard if the boiler cannot cope with zero flow.
- Valve for expansion tank, must be locked in open position.
- For boiler placed at a higher level than consumers, a level guard is required

The boiler:

- can cope with zero flow, from a safety viewpoint
- has two built-in thermostats.
- has a built-in level sensor.
- can be supplied with factory installed safety equipment.

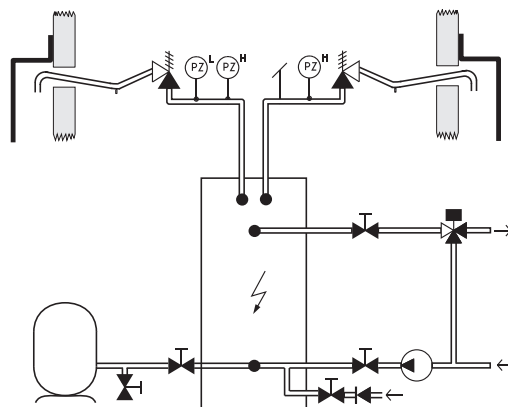

Safety valves are fitted with pressure guards and an automatic vent valve on the boiler's safety pipe.

The discharge pipe of the safety valve shall lead to a safe place in accordance with the requirements of SS EN 12828. Normally, this means on the outside of the building or in a flash tank.

The discharge pipe from the safety valve shall be dimensioned so that the blow-off capacity is not impeded.

The discharge pipe must be laid so it cannot freeze, must be cleaned well and must be laid so that water pockets cannot form. DN 10 drainage must be provided if there is a risk of standing water in the safety valve outlet line.

# Electrical installation



**Electrical installation must be carried out in accordance with the applicable regulations, by an authorised electrical installer or by someone who is covered by the company's self-inspection programme!**

**Cables must be dimensioned according to the Electrical Installation Rules.**

**Cables must be laid so that it is possible to open the front and remove the roof plate for service.**

**For minimum ceiling height, see Technical data.**

**Low-voltage cables may not be routed adjacent to power lines as this may give rise to interference.**

**The boiler and heating system must be filled with water and vented before the boiler is connected to the power supply.**



**Do not drill into the boiler's cover plates. Swarf can damage the boiler's electrical equipment!  
M6 bolts are available for fastening cable trays.**

## Power supply to external unit

230V~, max load 2 A

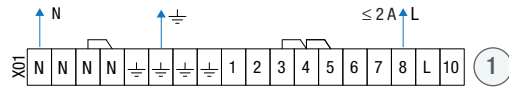

## Circulation pump

**See 'CP Function' IN THE INSTALLATION MENU!**

Potential-free closing contact for control to circulation pump, max. load 230 V~, 2 A.

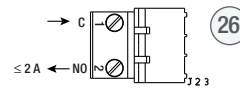

**The circulation pump must be labelled to show that it is controlled by the boiler if the function is used!**

## Operating voltage

The control side of the boiler is supplied with 230V~, 6 A fused, as shown in the figure below.

**The boiler must be preceded by an all-pole switch with at least 3 mm breaking distance!**

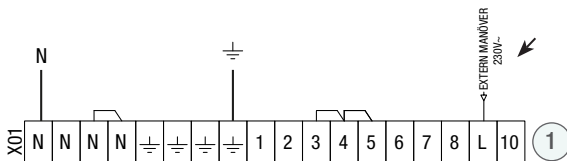

## External alarm indication

Buzzer alarm for external alarm indication of low water level, overheating protection triggered, PEC or safety equipment triggered. Potential-free alternating contact, max. 230 V~, 2 A.

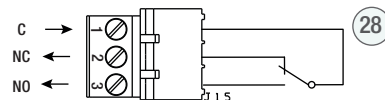

Terminals 1 - 2, C - NC, closed during operation.

Terminals 1 - 3, C - NO, closed during alarm.

## Power supply

Connection for PEN 4-core cable. Connection is made on switch and earth block/clamp.

Tightening torque: switch: 31 Nm  
earth block: 40 Nm

**Aluminium cable must be greased with neutral contact grease!**



# Electrical installation

## Pressure guards - Safety equipment



**To ensure that the boiler's safety system works as intended, external safety equipment must be connected as shown below!**

If the boiler was supplied without pressure guards, the installation must be supplemented with pressure guards. Connection as shown in the figure.

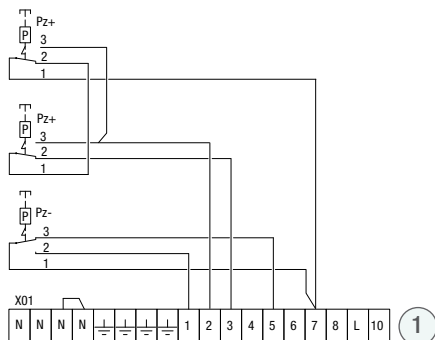

Pz- low pressure guard  
Pz+ high pressure guard

Alternatively, if the boiler can share the safety equipment with other boilers in the installation.

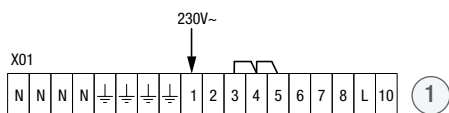

The alarm signal, 230 V~, from existing safety equipment, is connected to terminal 1.

**Please note that the alarm signal must be of the same phase as that used for the boiler's control!**

### Load guard

The current transformers need not be connected if the function is not to be used. The guard is not phase-sensitive.

**See 'CURRENT LIMIT' and 'MARGIN' IN THE INSTALLATION MENU!**

Measurement is with primary and secondary current transformers. The latter are supplied with the boiler. The system-adapted primary current transformers, xxx/5 A, are supplied by the electrician. The cable from the primary current transformer must pass through the secondary current transformer once.

Connection to terminal block J10, with a common conductor in terminal J10:4.



**The secondary current transformers must be connected to the circuit board before the cable from the primary current transformer is routed through them!**

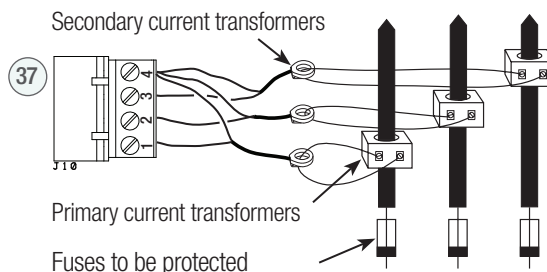

## Restart after power cut

The boiler requires manual restart after a power cut.



**Disconnection of the function must be evaluated in collaboration with the end-user and accepted by the accredited body that assesses the periodic monitoring of the boiler.**

## Reconnection

Move cable marked "22":

- From: START button (2), terminal "13"
- To: STOP button (3), terminal "14".

Before reconnection:

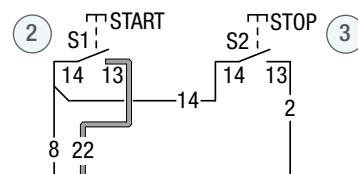

After reconnection:

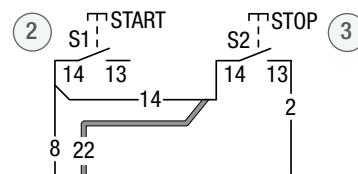

**All other cables should remain in their positions!**

The boiler will start automatically when the voltage returns after a voltage loss.

# Electrical installation

## External blocking

See **'EXT. STAGE LIMIT' IN THE INSTALLATION MENU!**

The boiler can be blocked by an external potential-free contact.

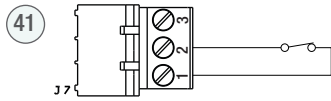

## External stage control — 0 - 10 V, 0 - 5 V or 4 - 20 mA

See **'EXT. STAGE LIMIT' IN THE INSTALLATION MENU!**

0-100% of installed power. Installed power is the number of stages the boiler is permitted to use.

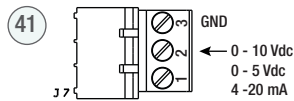

## External setpoint — 0 - 10 V, 0 - 5 V or 4 - 20 mA

See **'EXT. TEMP. SETPOINT' IN THE INSTALLATION MENU!**

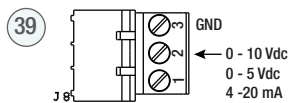

## 0 - 10 V output signal of connected power

0-10 V, equivalent to 0-100% of installed power.

Installed power is the number of stages the boiler is permitted to use.

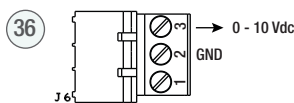

## 0 - 10 V output signal of boiler temperature

0- 10 V is equivalent to 0-170°C.

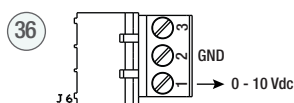

## Outdoor temperature sensor - boiler with UTK

See **ADJUSTMENT MENU!**

The temperature sensor is fitted to an outside wall, at half the height of the façade, close to a corner, facing north/north west. The sensor must not be placed where it will be exposed to the morning sun or close to valves, windows or doors. Connection with at least 0.4 mm<sup>2</sup> cable up to 30 metres. The duct is sealed so as to avoid condensation in the sensor enclosure.

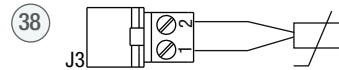

## Alternative heating - boiler with UTK

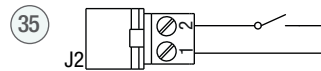

See **"EXT. TEMP. ADJUST" IN THE INSTALLATION MENU** and **"TEMP. ADJUST" IN THE ADJUSTMENT MENU!**

The temperature can be changed with the aid of an external potential-free contact function, protective extra low voltage.





# Wiring diagram - control circuit

- Terminal block, control circuit. Terminals 1, 3, 4 and 5: connection safety equipment. Terminal 8: 230 V supply to external unit.
- 'START' button.
- 'STOP' button. When pressed, it cuts the power supply to the boiler by tripping the load-break switches.
- Panel circuit board with overlay.
- Ribbon cable with ferrite terminals.
- Thermostat one.
- Thermostat two.
- Zero voltage relay.
- Load-break switch, B1, with auxiliary switch.
- Load-break switch, B2, with auxiliary switch.
- Contactor, K1, for power group one.
- Contactor, K2, for power group two.
- Contactor, K3, for power group three.
- Contactor, K4, for half power group four.
- Contactor, K5, for half power group four.
- Contactor, K6, for part of power group five.
- Contactor, K7, for part of power group five.
- Contactor, K8, for part of power group five.
- Contactor, K9, for part of power group five. Included in EP 540, 600, 700 and 750 TL only.
- Circuit board, power.
- Sense inputs, sense the status of thermostats and high pressure guards.
- Indication, lights up when;
  - A: the circuit board has voltage.
  - B: the thermostats are in operating mode.
  - C: high pressure guards are in operating mode (option).
- Sense inputs, sense the status of load-break switches, low pressure guard and zero voltage relay.
- Indication, lights up when;
  - A: the load-break switches are in operating mode.
  - B: low pressure guard is in operating mode (option).
  - C: zero voltage relay is in operating mode.
- Relay outputs for the boiler's power groups.
- Potential-free relay output for circulation pump. Max. load 230 V~/2 A.
- Potential-free relay output for cooling fan. Max. load 230 V~/2 A. A fan is included in EP 450, -510 and 700 TL, optional for other models.
- Potential-free relay output for buzzer alarm.
- Outputs for control of SSR, option.
- Boiler temperature sensor, J12.
- Temperature sensor, J13, only in boiler with cooling fan, option (see point 27).
- Temperature sensor, J14, only included in boiler for secondary control, option.
- Alternative connection for temperature sensor 42, the sensor is connected to terminals 3 and 4.
- Pt100 boiler temperature sensor, J1, only in high temperature boilers, option.
- Alternative temperature using external contact function, only with outdoor temperature compensator, option. Alternatively Pt100 temperature sensor, J2, only in high temperature boilers, option.
- Output signal, current power and boiler temperature.
- Connection for the load guard's current transformers.  
 **The circuit board may be damaged, the current transformer must be short-circuited when switching on/off!**
- Outdoor temperature sensor, J3, only in boiler with outdoor temperature compensator, option.
- Connection for external setpoint setting.
- Level sensor connection.
- Connection for external stage control.
- Connection of current transformer for PEC function.  
 **The circuit board may be damaged, the current transformer must be short-circuited when switching on/off!**
- Ribbon cable connection for panel circuit board.
- Ribbon cable connection for series control of boilers, option.
- Ribbon cable connection for series control of boilers, option.

*Included in boilers delivered with safety equipment!*

- Terminal block for pressure guards.
- High pressure guard one.
- High pressure guard two.
- Low pressure guard.



**The control voltage is not broken by the load-break switches! External voltage may occur.**

# Wiring diagram - control circuit

for the user

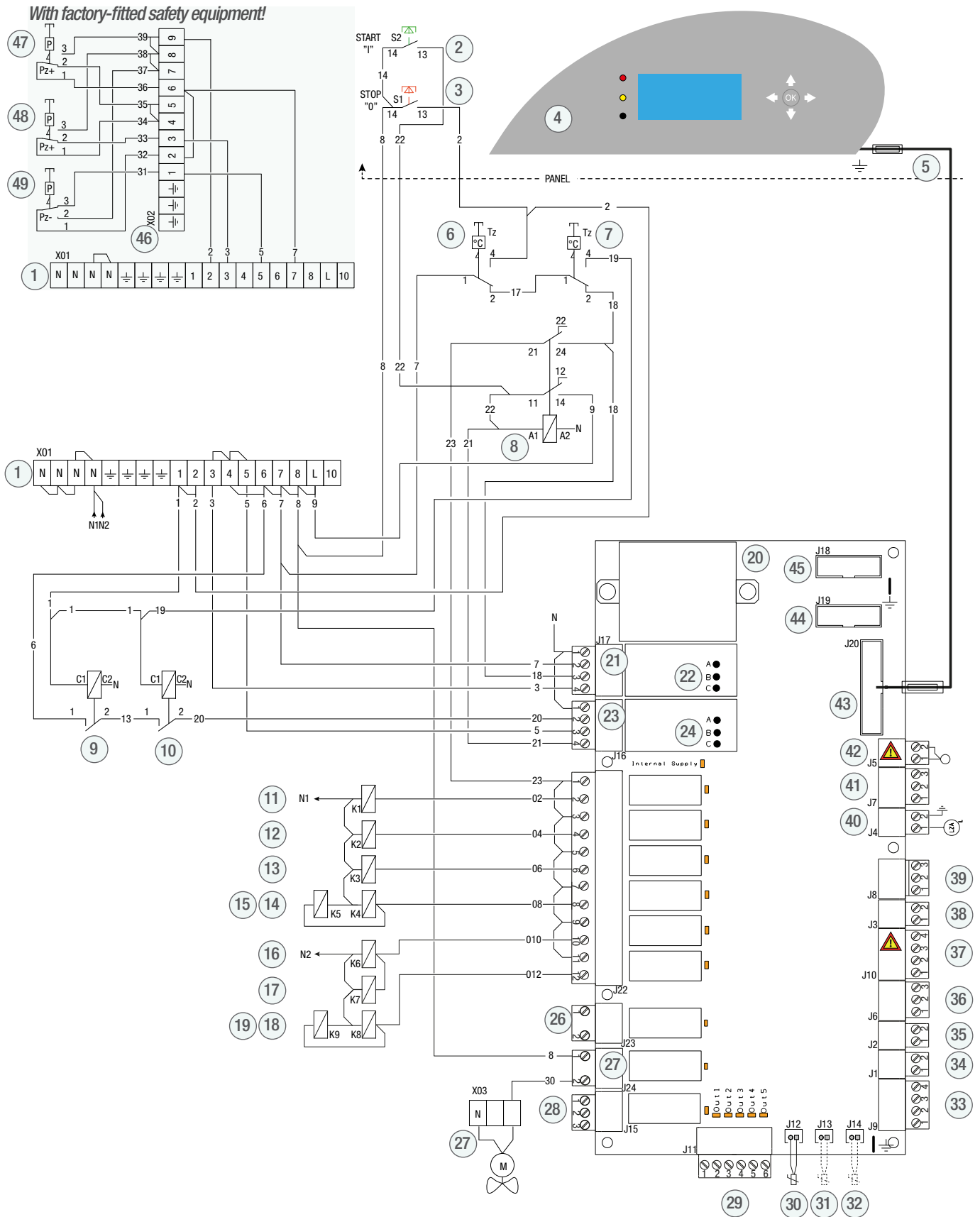

**STOP** Any intervention in the boiler's electrical equipment that requires tools must be carried out under the supervision of a qualified electrician!

# Wiring diagram - power circuit EP 450 and 510 TL

## EP 450 TL

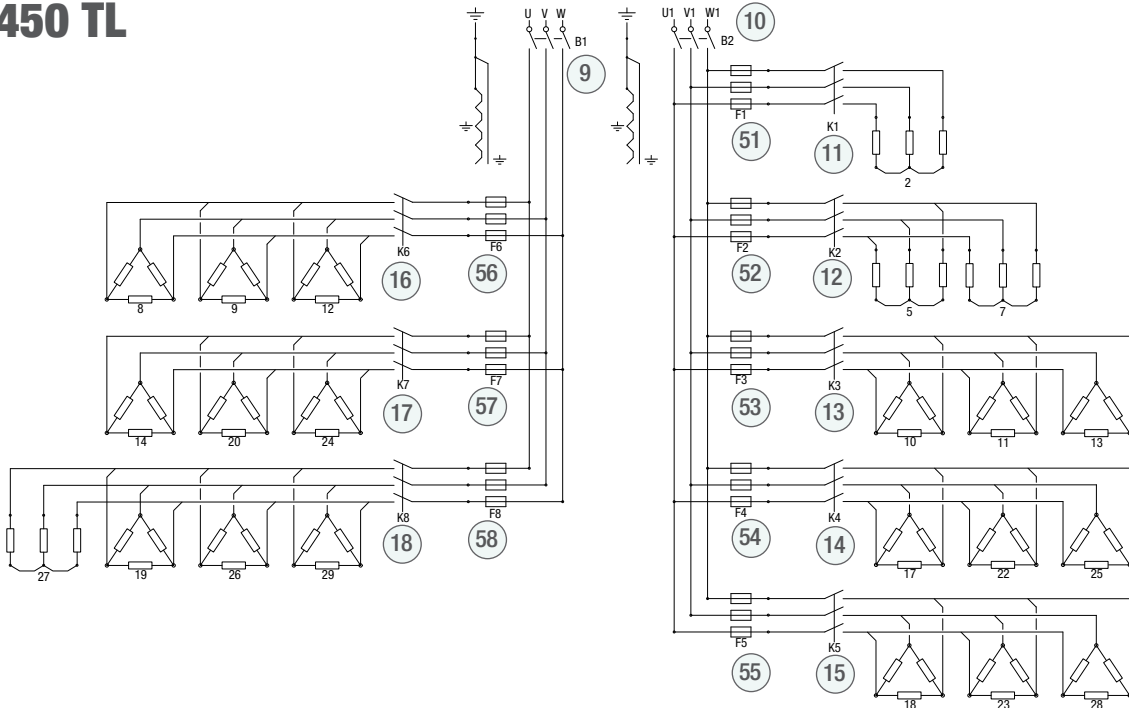

## EP 510 TL

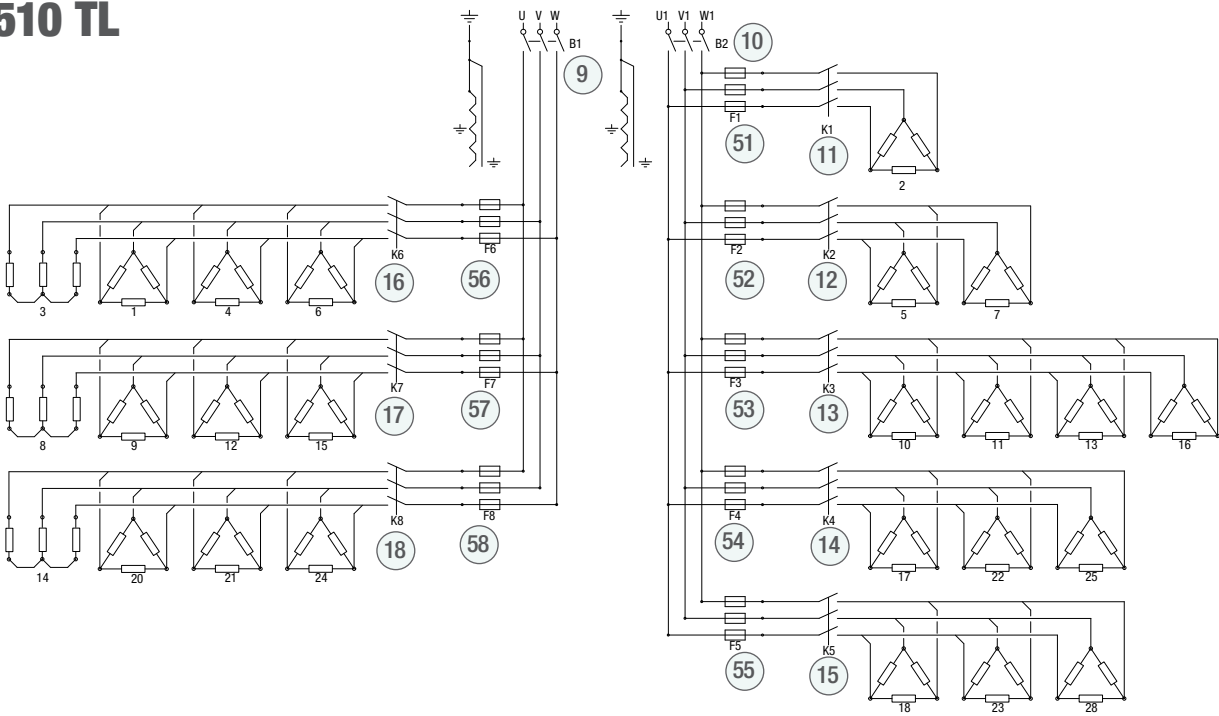

	Power group 1	Power group 2	Power group 3	Power group 4	Power group 5
<b>EP450TL</b>					
<b>Contactor</b>	K1 (11)	K2 (12)	K3 (13)	K4 (14), K5 (15)	K6 (16), K7 (17), K8 (18)
<b>Immer- sion heater</b>	2	5, 7	10, 11, 13	K4: 17, 22, 25 K5: 18, 23, 28	K6: 8, 9, 12; K7: 14, 20, 24 K8: 27, 26, 29, 19
<b>Output</b>	15 kW	2 × 15 kW	3 × 20 kW	6 × 20 kW	3 × 23.3 kW 15 kW + 3 × 23.3 kW
<b>Immer- sion heater</b>	2	5, 7	10, 11, 13, 16	K4: 17, 22, 25 K5: 18, 23, 28	K6: 3, 1, 4, 6; K7: 8, 9, 12, 15 K8: 14, 20, 21, 24
<b>Output</b>	15 kW	30 kW	60 kW	120 kW	15 kW + 3 × 23.3 kW 224.7 kW
<b>Fuse</b>	F1 (51)	F2 (52)	F3 (53)	F4 (54), F5 (55)	F6 (56), F7 (57), F8 (58)
<b>Switches</b>	3 × 35 A	3 × 80 A	3 × 125 A	2 pcs 3 × 125 A	3 pcs 3 × 160 A

B1(9), B2 (10)

# Wiring diagram - power circuit EP 540, -600, -700 and 750 TL

for the user

**EP 750 TL 690V~**  
**All immersion heaters**  
**Y-connected.**

**EP 540 and -700 TL: 400V 3~EP 600**  
**TL: 400V3~ alt. 690V3~ See rating plate EP 750**  
**TL: 690V 3~**

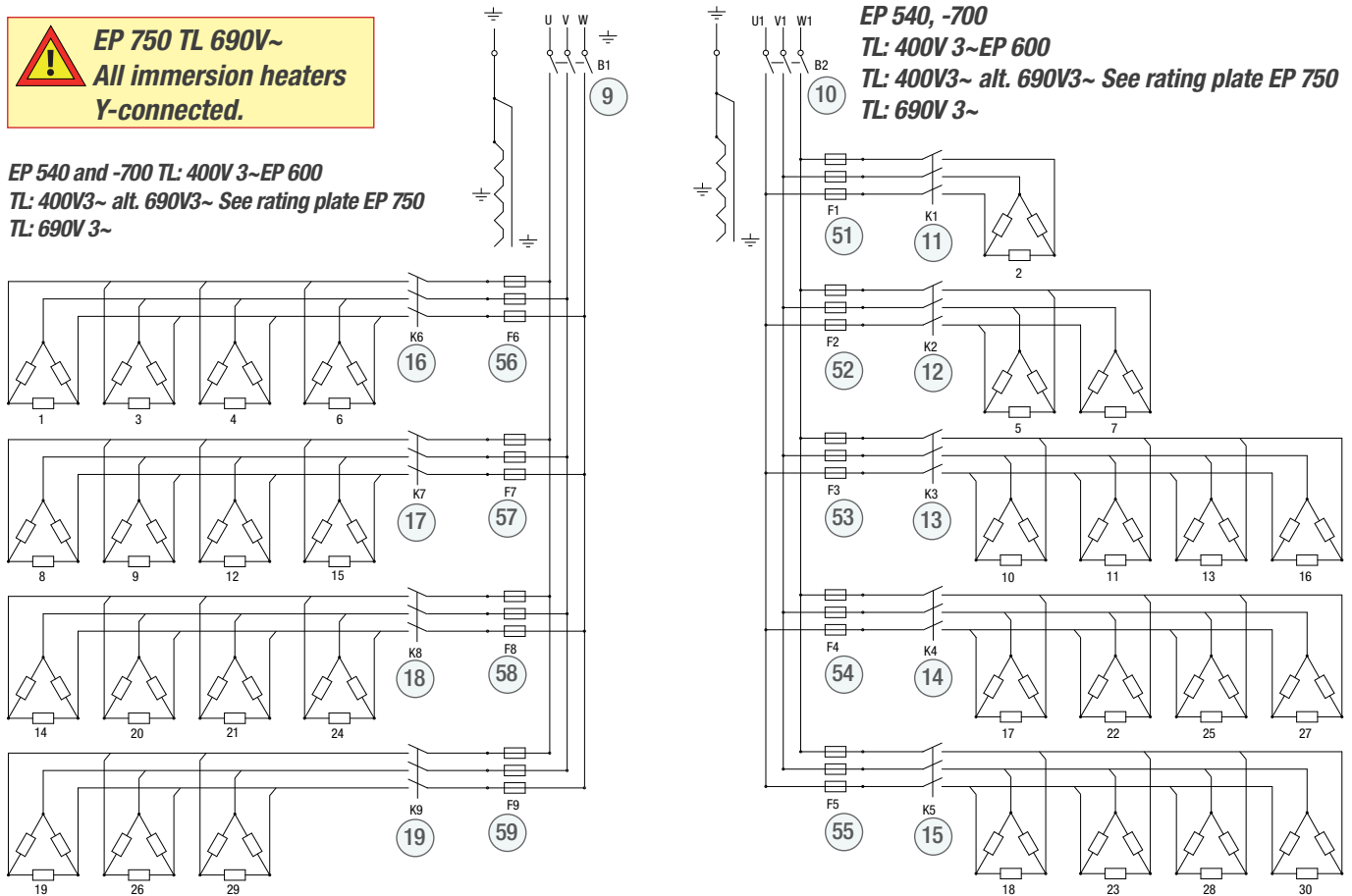

	Power group 1	Power group 2	Power group 3	Power group 4	Power group 5
<b>Contactor</b>	K1 (11)	K2 (12)	K3 (13)	K4 (14), K5 (15)	K6 (16), K7 (17), K8 (18), K9 (19)
<b>Immersion heater</b>	2	5, 7	10, 11, 13, 16	K4: 17, 22, 25, 27 K5: 18, 23, 28, 30	K6: 1, 3, 4, 6 K7: 8, 9, 12, 15 K8: 14, 20, 21, 24 K9: 19, 26, 29
<b>EP 540 TL</b>	18 kW (18 kW)	36 kW (2 × 18 kW)	72 kW (4 × 18 kW)	144 kW (8 × 18 kW)	270 kW (15 × 18 kW)
<b>EP 600 TL</b>	20 kW (20 kW)	40 kW (2 × 20 kW)	80 kW (4 × 20 kW)	160 kW (8 × 20 kW)	300 kW (15 × 20 kW)
<b>EP 700 TL</b>	23.3 kW (23.3 kW)	46.6 kW (2 × 23.3 kW)	93.2 kW (4 × 23.3 kW)	186.4 kW (8 × 23.3 kW)	349.5 kW (15 × 23.3 kW)
<b>EP 750 TL</b>	25 kW (25 kW)	50 kW (2 × 25 kW)	100 kW (4 × 25 kW)	200 kW (8 × 25 kW)	375 kW (15 × 25 kW)
<b>Fuse</b>	F1 (51)	F2 (52)	F3 (53)	F4 (54), F5 (55)	F6 (56), F7 (57), F8 (58) F9 (59)
<b>EP 540 TL</b>	3 × 35 A	3 × 80 A	3 × 160 A	Two groups 3 × 160 A	Three groups 3 × 160 A
<b>EP 600 TL</b>	3 × 50 A	3 × 80 A	3 × 160 A	Two groups 3 × 160 A	Three groups 3 × 160 A
<b>TL400V3~</b>					
<b>EP 600 TL</b>	3 × 35 A	3 × 50 A	3 × 80A	Two groups 3 × 80 A	Three groups 3 × 80 A
<b>TL690V3~</b>					
<b>EP 700 TL</b>	3 × 50 A	3 × 100 A	3 × 160 A	Two groups 3 × 160 A	Three groups 3 × 160 A
<b>EP 750 TL</b>	3 × 35 A	3 × 80	3 × 100 A	Two groups 3 × 100 A	Three groups 3 × 100 A
<b>TL690V3~</b>					
<b>Switches</b>	B1 (9), B2 (10)				

## Location on top of boiler vessel

Figures state location of immersion heaters.

- A. Temperature sensor
- B. Thermostat
- C. Level sensor
- D. Manometer connection

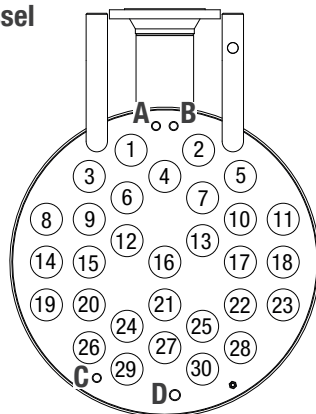

**The control voltage is not broken by the load-break switches! External voltage may occur.**

**To break the power supply to the boiler, both load-break switches, 9 and 10, must be placed in the 0 position. Lock the switches.**

## Technical Data

*The electric boiler is CE marked as a unit and is classified as pressure equipment according to Directive 2014/68/EU, Article 4(3).*

*The electric boiler can be supplied with factory-fitted safety equipment, reviewed by accredited body according to EN 12828. Factory-fitted safety equipment includes: 2 x safety valves. 2 x high pressure guards. 1 x low pressure guard. 1 x automatic vent valve.*

*With factory-fitted safety equipment, the boiler can be installed without expansion tank according to EN 12828.*

*Double circulation pumps and flow guards are not required. The boiler can cope with zero flow from a safety perspective.*

*A steam-collecting vessel is not required. The safety valves are fitted directly on the boiler's safety pipe.*

*Final examination, under national laws, that the electric boiler has the necessary safety equipment shall be carried out by an accredited body when assessing the monitoring interval for the electric boiler.*



# Technical Data

Type	EP 450 TL	EP 510 TL	EP 540 TL	EP 600 TL	EP 700 TL	EP 600 TL	EP 750 TL	
Article number	6955	6956	6957	6958	6960	4738	6961	
RSK								
Voltage power operation	400V3~ 230V~				690V3~ 230V~			
Voltage tolerance	≤ ±10							%
Frequency	50 / 60							Hz
Enclosure class	IP x1							
Power	450	510	540	600	700	600	750	kW
Current	648	735	778	865	1009	502	627	A
Fuse power, ≤	4 groups of 200	4 groups of 250			4 groups of 300	4 groups of 200	4 groups of 200	A
operation	6							A
Number of stages	30, can be limited down to 1 stage							
Power/stage, stage size	15	17	18	20	23.3	20	25	kW
Current/stage	21.6	24.5	26	28.8	33.6	16.7	20.9	A
Cable flange	2 x FL 33, 2 x Ø60 mm							
Cable connection	4 x 95 - 240 Al/Cu <i>Up to 240 mm² round-pressed cable can be connected.</i>							
Volume	315							litre
Calculation pressure	0.66							MPabar
Test pressure	0.868.6							MPabar
Calculation temperature	110							°C
Operating temperature	20 - 100							°C
Ambient temperature	boiler without fan ≤ 30 boiler with fan ≤ 40							°C
Connection, flow/return	DN 100 PN 16							
Safety pipe	2 x R32 ext.							
Flow requirements, Δt = 10°C min/max	10,7 4,3/18	12,2 4,9/18	12,9 5,2/18	14,3 5,7/18	16,7 6,7/18	14,3 5,7/18	17,9 6,7/18	litres/sec litres/sec
Weight empty water filled	467 782	470 785	470 785	485 800	500 815	485 800	490 805	kg kg
Pressure drop								
Ceiling height for immersion heater replacement	>2430							mm
Manufactured to	PED 2014/68/EU article 4.3							

# Technical Data

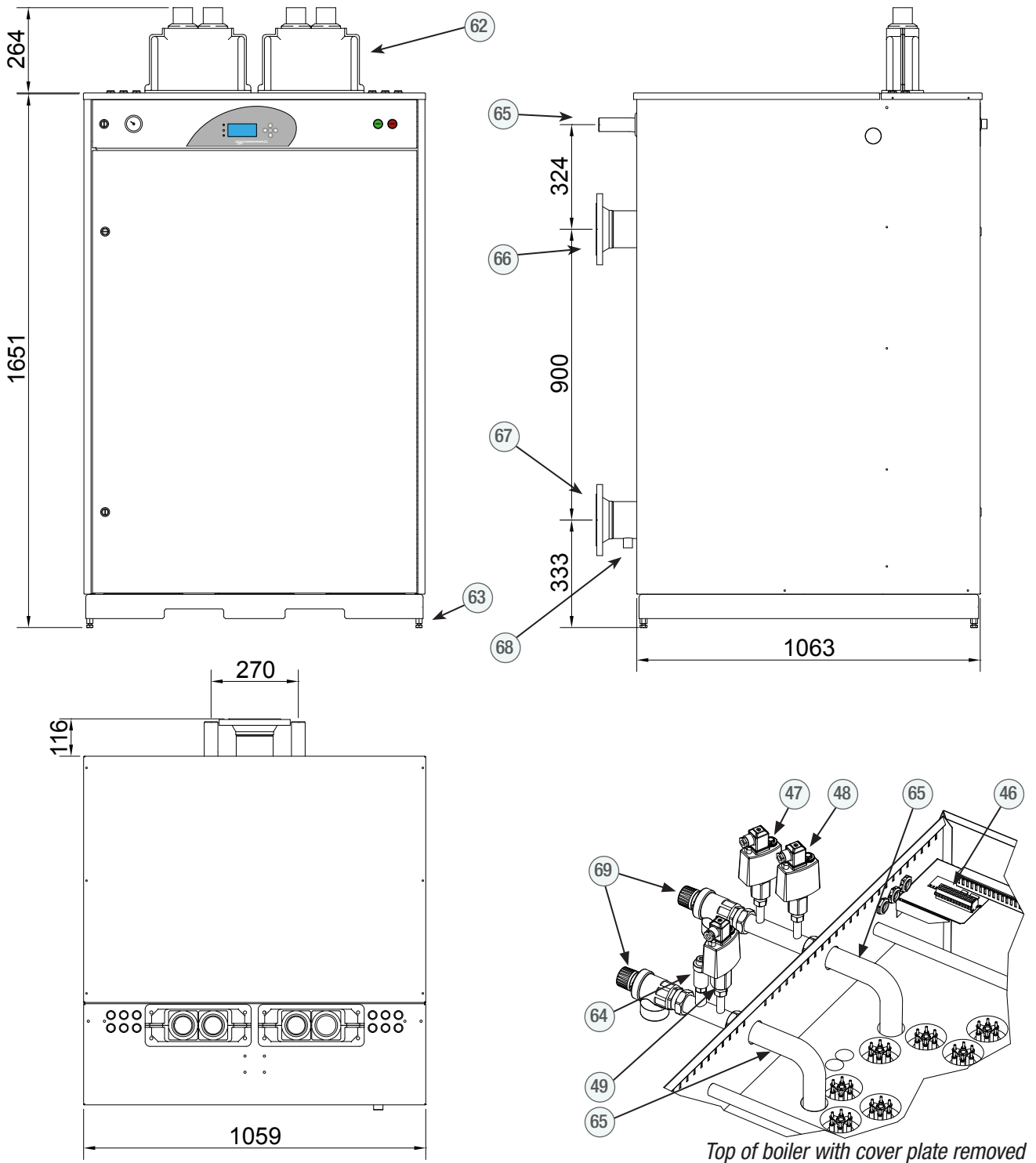

- 46. Terminal block for pressure guards.\*
- 47 High pressure guard one.\*
- 48. High pressure guard two.\*
- 49. Low pressure guard.\*
- 62. Cable flanges.
- 63. Adjustable foot bolts.
- 64. Automatic vent valve.\*

- 65. Safety pipes.
- 66. Flow connection.
- 67. Return connection.
- 68. Drain/valve.
- 69 Safety valves, 2\*

\* Included in factory-fitted safety equipment, option.

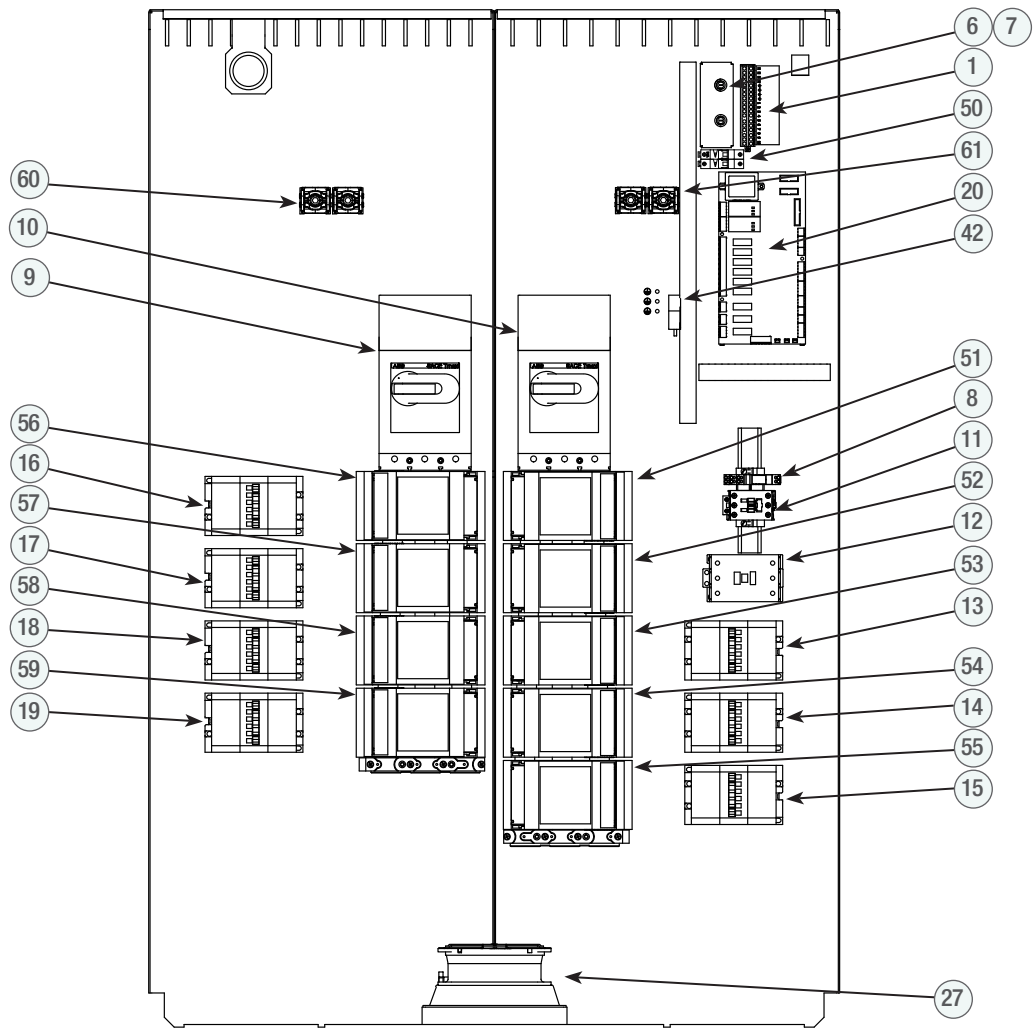

The figure is for illustration, there are differences between boiler models

- |  |   |
|--|---|
| <ul style="list-style-type: none"> <li>1. Terminal block, control circuit.</li> <li>6. Thermostat one.</li> <li>7. Thermostat two.</li> <li>8. Zero voltage relay.</li> <li>9. Load-break switch, B1, power group 5.</li> <li>10. Load-break switch, B2, power groups one to four.</li> <li>11. Contactor, K1, power group one.</li> <li>12. Contactor, K2, power group two.</li> <li>13. Contactor, K3, power group three.</li> <li>14. Contactor, K4, half power group four.</li> <li>15. Contactor, K5, half power group four.</li> <li>16. Contactor, K6, part of power group five.</li> <li>17. Contactor, K7, part of power group five.</li> <li>18. Contactor, K8, part of power group five.</li> <li>19. Contactor, K9, part of power group five in EP 540 - 750 TL.</li> <li>20. Circuit board, power.</li> </ul> | <ul style="list-style-type: none"> <li>27. Cooling fan is included in EP 450, -510 and 700 TL, otherwise optional.</li> <li>42. Current transformer, PEC function.</li> <li>50. Connection 230V~ operating voltage, fuse, 6 A</li> <li>51. Blade fuse/holder, F1, fuse power group one.</li> <li>52. Blade fuse/holder, F2, fuse power group two.</li> <li>53. Blade fuse/holder, F3, fuse power group three.</li> <li>54. Blade fuse/holder, F4, fuse part of power group four.</li> <li>55. Blade fuse/holder, F5, fuse part of power group four.</li> <li>56. Blade fuse/holder, F6, fuse part of power group five.</li> <li>57. Blade fuse/holder, F7, fuse part of power group five.</li> <li>58. Blade fuse/holder, F8, fuse part of power group five.</li> <li>59. Blade fuse/holder, F9, fuse part of power group five, only in EP 540 - 750 TL.</li> <li>60. Connection, PE conductor, power group five.</li> <li>61. Connection, PE conductor, power groups one to four.</li> </ul> |
|--|---|

# Troubleshooting

## Irregular operation

The electric boiler increases a few stages and is then reduced immediately, etc.

Water flow through the electric boiler too low.

Check that circulation pumps and valves are working.

This is an easy way to get an idea of the level of flow through the boiler:

- Limit the power stages of the boiler so that the power is constant, for example to one power stage.
- Let the boiler's temperature become stable.
- Measure the temperature increase between the flow and return lines of the boiler.
- Calculate the flow through the boiler using the formula below.
- Check against the details in "Data" whether the flow is adequate.

$$q = \frac{P}{\Delta t \times 1,16}$$

q	=	water flow in m <sup>3</sup> /h. (m <sup>3</sup> /h x 1000/3600 = litres/second)
P	=	electric boiler's power output in kW
Δt	=	temperature difference between the boiler's flow and return line in °C.
1.16	=	the water's thermal absorption coefficient.

## Tables for temperature sensors

When the resistance of a temperature sensor is measured, it must be disconnected from the circuit board.

For voltage measurement of sensors J12 = Boiler temperature sensor, 30.

J13 = Temperature sensor, 31, boiler with cooling fan, option.

J14 = Temperature sensor, 32, for secondary control, option.

Also terminals 3 - 4 in terminal block 33.

if there are measuring points on the circuit board with connections. The voltage of other temperature sensors is measured in their connection to the terminal block.

### Temperature sensors, J12, J13 and J14

°C	kΩ	V	°C	kΩ	V	°C	kΩ	V
5	141.9	4.7	45	24.6	3.6	85	5.9	1.9
10	111.6	4.6	50	20.2	3.3	90	5	1.7
15	88.3	4.5	55	16.7	3.1	95	4.3	1.5
20	70.3	4.4	60	13.9	2.9	100	3.7	1.3
25	56.3	4.3	65	11.6	2.7	105	3.2	1.2
30	45.4	4.1	70	9.7	2.5	110	2.7	1
35	36.8	3.9	75	8.2	2.3			
40	30	3.8	80	6.9	2.0			

### Pt100 temperature sensor, option

°C	Ω	V	°C	Ω	V
5	101.9526	0.4626	85	132.799	0.5862
10	103.9022	0.4706	90	134.7022	0.5936
15	105.849	0.4786	95	136.6026	0.6009
20	107.7928	0.4865	100	138.5	0.6083
25	109.7338	0.4944	105	140.3945	0.6156
30	111.6718	0.5023	110	142.2862	0.6228
35	113.607	0.5101	115	144.1749	0.6300
40	115.5392	0.5179	120	146.0608	0.6372
45	117.4686	0.5256	125	147.9437	0.6444
50	119.3951	0.5333	130	149.8237	0.6515
55	121.3186	0.5410	135	151.7009	0.6586
60	123.2392	0.5486	140	153.5751	0.6656
65	125.157	0.5562	145	155.4464	0.6727
70	127.0718	0.5637	150	157.3149	0.6797
75	128.9838	0.5712	155	159.1804	0.6866
80	130.8928	0.5787	160	161.043	0.6935

### Outside temperature sensor, option

°C	kΩ	V	°C	kΩ	V
-30	47	4.3	5	6.8	2.4
-25	34.7	4.1	10	5.4	2.1
-20	25.9	3.9	15	4.2	1.8
-15	19.5	3.6	20	3.4	1.6
-10	14.8	3.3	25	2.7	1.3
-5	11.4	3.0	30	2.2	1.1
0	8.8	2.7			

## Components

EP-		400V 3~					690V 3~	
		450 TL	510 TL	540 TL	600 TL	700 TL	600 TL	750 TL
<b>Immersion heater</b>								
110035	15 kW/400V	4	3	-	-	-	-	-
110036	17 kW/400V	-	7	-	-	-	-	-
110037	18 kW/400V	-	-	30	-	-	-	-
110038	20 kW/400V	9	1	-	30	-	-	-
110039	23.3 kW/400V	9	14	-	-	30	-	-
110091	20 kW/690V	-	-	-	-	-	30	-
119155	25 kW/690V	-	-	-	-	-	-	30
<b>Load-break switch</b>								
130067		2	-	-	-	-	2	2
130068		-	2	2	2	2	-	-
<b>Contactors</b>								
170080		K6 - K8	K3 - K8	K3 - K8	K3 - K8	K3 - K9	-	-
170081		K3 - K5	-	K9	K9	-	K3 - K9	K3 - K9
170085		K1	K1	K1	K1	K1	K1	K1
170087		K2	K2	-	-	-	K2	K2
170088		-	-	K2	K2	K2	-	-
<b>Blade fuse</b>								
180060	35 A	F1	F1	F1	-	-	F1	F1
180061	50 A	-	-	-	F1	F1	F2	-
180063	80 A	F2	F2	F2	F2	-	F3 - F9	F2
180064	100 A	-	-	F9	-	F2	-	F3 - F9
180065	125 A	F3 - F5	F3 - F5	-	F9	-	-	-
180066	160 A	F6 - F8	F6 - F8	F3 - F8	F3 - F8	F3 - F9	-	-
<b>Fan</b>								
500030		1	1	-	-	3	-	-
<b>Temperature sensor to fan</b>								
210206		1	1	-	-	1	-	-

### Common components

210314	Circuit board, panel	1	130036	Pressure switch green, "I"	1
700415	Overlay, panel circuit board	1	170008	Zero voltage relay	1
210313	Circuit board, power	1	240350	Drain valve	1
218010	Ferrite terminal	2	380023	Manometer	1
700564	Temperature sensor	1	380002	Non return valves	1
360020	Current transformer, PEC	1	300016	O-ring 9.25 x 1.78	1
440040	Level sensor	1	300017	O-ring, seal immersion heater/blind plug	1
360020	Current transformer for load guard	3			
120022	Thermostat	2			
130034	Pressure switch red, "O"	1			

# Option

1909	UTK 7/15/30 outside temperature compensator, complete	
210211	Outside temperature sensor for UTK	
4801	Fan kit EP 135 - 750, one fan, assembly	
4802	Fan kit EP 135 - 750, extra fan, assembly	
500030	Fan for 4801 and 4802	1
500031	Filter for 4801 and 4802	1
210206	Temperature sensor for 4801 and 4802	1
4804	Secondary control EP31 - 750, assembly	
210203	Temperature sensor for 4804	1
4803	Series control two boilers EP31 - 750, assembly	

4795245076	Safety equipment open system, EP 350 - 750, contains:Non-return valve for air vent	1
245078	Air vent	1
440196	High pressure guard	1
440197	Low pressure guard	1

Safety equipment closed systemContents, in addition to some of the below specified safety valves:

245076	Non-return valve for air vent	1
245078	Air vent	1
440196	High pressure guard	2
440197	Low pressure guard	1

4859	Safety equipment EP 350 - 450 3 bar	2
245511	Safety valve, 3 bar	
4885	Safety equipment EP 350 - 450 1.5 bar	2
245517	Safety valve, 1,5 bar	
4888	Safety equipment EP 350 - 540 4 bar	2
245512	Safety valve, 4 bar	
4891	Safety equipment EP 450 - 540 2.5 bar	2
245516	Safety valve, 2.5 bar	
4892	Safety equipment EP 510 - 750 3 bar	2
245515	Safety valve, 3 bar	
4894	Safety equipment EP 600 - 750 4 bar	2
245518	Safety valve, 4 bar	
4893	Safety equipment EP 450 - 750 6 bar	2
245513	Safety valve, 6 bar	





 **VÄRMEBARONEN**  
Värmebaronen AB  
Arkelstorpsvägen 88  
SE-291 94 Kristianstad  
Tel. + 46 44 22 63 20  
[www.varmebaronen.se](http://www.varmebaronen.se)  
[info@varmebaronen.se](mailto:info@varmebaronen.se)